

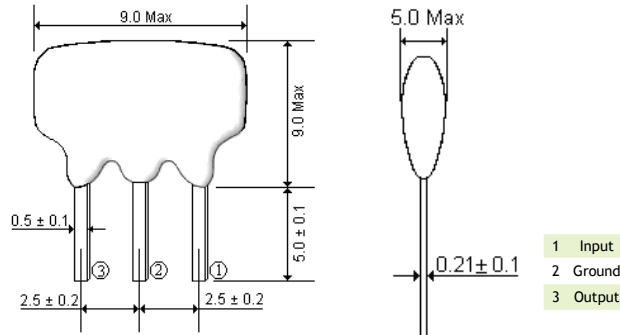

DESCRIPTION

XT...MB Series are band reject type used for video and sound IF attenuation. The 3 terminal XT...MB Series contains 2 elements on one substrate for additional attenuation. XT MB Series can be used in the sound IF of CATV/VCR receivers.

MECHANICAL DIMENSIONS (all in mm) XT...MB



ELECTRICAL SPECIFICATION (for TV/VCR) - Table 1

Part Number	Center Frequency In (MHz)	-30dB Bandwidth In (kHz)	Trap Attenuation at Nominal Frequency In (dB)
XT4.5MB	4.5	≥ 50	≥ 35
XT5.5MB	5.5	≥ 70	≥ 35
XT6.0MB	6.0	≥ 70	≥ 35
XT6.5MB	6.5	≥ 70	≥ 35

XT...MB SERIES CHARACTERISTICS

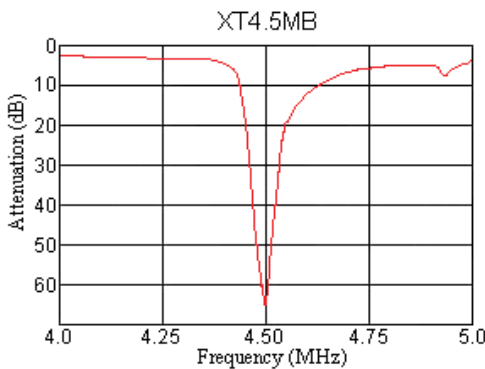

TEST CIRCUITS XT...MB

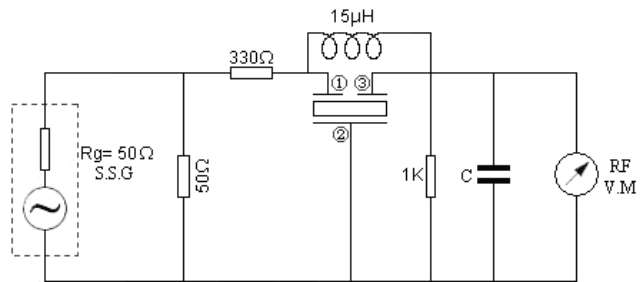

PART NUMBERING SYSTEM (Example)

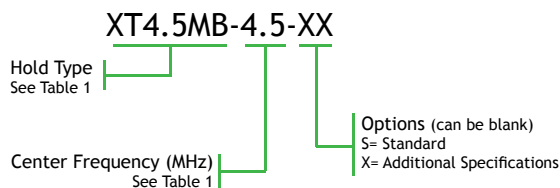

Operating Temperature Range: 0 to 60°C (Standard)
Specific Operating Temperature Range under request.