

阻值允许误差 Tolerance of resistance	$\pm 20\%$	总机械旋转角度 Total rotation angle	$300 \pm 5^\circ$
额定功率 power Rating	0.1W / 0.05W	动作力 Operating force	20~200gf.cm
额定电压 Rated voltage	50V AC/BC 20V	止挡强度 Shaft Stopper Strength	4Kgf/cm min
转动噪声 Rotational noise	$\leq 47\text{mv}$	绝缘电阻 Insulation resistance	DC250V 100M Ω min
双联同步误差 Tracking error	B 0~-20db $\pm 2\text{db}$ A C D 0~-40db $\pm 3\text{db}$	耐电压 Withstanding Voltage	AC300V 1 minute
		机械耐久性 Mechanical endurance	10000 ^转 min turns

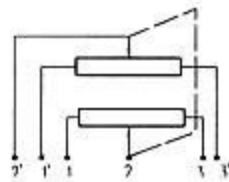

Standard Shaft Size:

● 18T

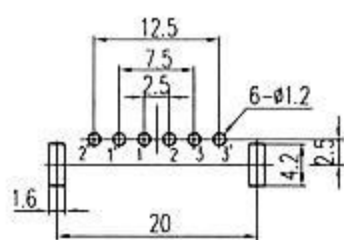
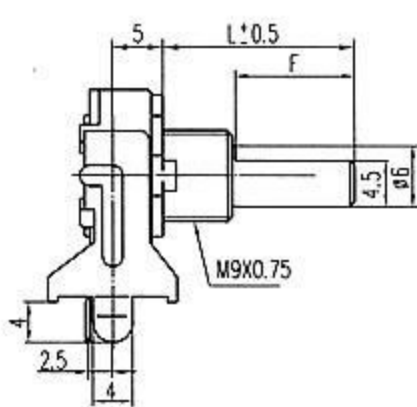
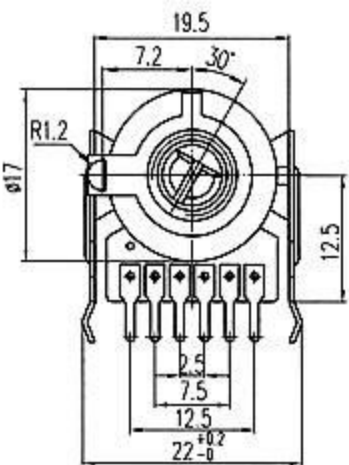
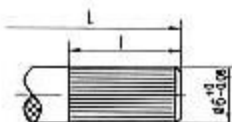

● F

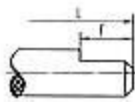

型号TYPE

F. I

L

WH0171-1

WH0171Z-1

WH0172-1

WH0172-2B-1

WH0171-2J

WH0172-2AJ

15

20

25

30

35

40

7

7

12

12

12

12

7

12

12

12

12