

## Current 1A High Voltage 40V Low Power LDO

### CYP7903

#### General Description

The CYP7903 series is a group of positive voltage output, three-pin regulators, that provide a high current even when the input/output voltage differential is small. Low power consumption and high accuracy is achieved through CMOS and laser trimming technologies.

The CYP7903 consists of a high-precision voltage reference, an error amplification circuit, and a current limited output driver. Transient response to load variations have improved in comparison to the existing series.



#### Features

- Low Quiescent Current: typical 1.6 $\mu$ A
- Temperature Stability:  $\pm 50$ ppm/ $^{\circ}$ C
- High input voltage: 40V
- Output voltage accuracy: tolerance  $\pm 2\%$
- Low temperature coefficient
- Dropout Voltage: 20mV@IOUT=10mA
- Maximum Output Current: 1A
- The chip has the functions of overheat protection, over current protection and output short circuit protection
- Packages: SOT89-3L, SOT223 and TO252

#### Applications

- Industrial control
- Smart meters, instruments and meters
- Battery supply set
- Wireless communication equipment

- Automotive electronics

## Order information

Product model	Package	Manner of packing	Minimum packing quantity
CYP7903PxxPx	SOT89-3L	Reel	1000
CYP7903PxxPBx	SOT89-3L(B)		1000
CYP7903PxxFx	SOT223		2500
CYP7903PxxFBx	SOT223(B)		2500
CYP7903PxxJx	TO252	Tube	2500

## Selection Guide Table

CYP7903P①②③④

Designator	Symbol	Description	Remarks
①②	Integer	Output Voltage(3.0V~12.0V)	For example, if the output voltage is 5.0V, ①② will be 50.
③	P	Package:SOT89-3L	The encapsulated pin definition is described in the pin assignment below.
	PB	Package:SOT89-3L(B)	
	F	Package:SOT223	
	FB	Package:SOT223(B)	
	J	Package: TO252	
④	R	RoHS / Pb Free	
	G	Halogen Free	

Note: "①②" stands for output voltages. The regular output voltage is 3V, 3.3V, 3.6V, 4.0V, 5.0V, 12V. Other voltages can be specially customized.

## Functional Block Diagram

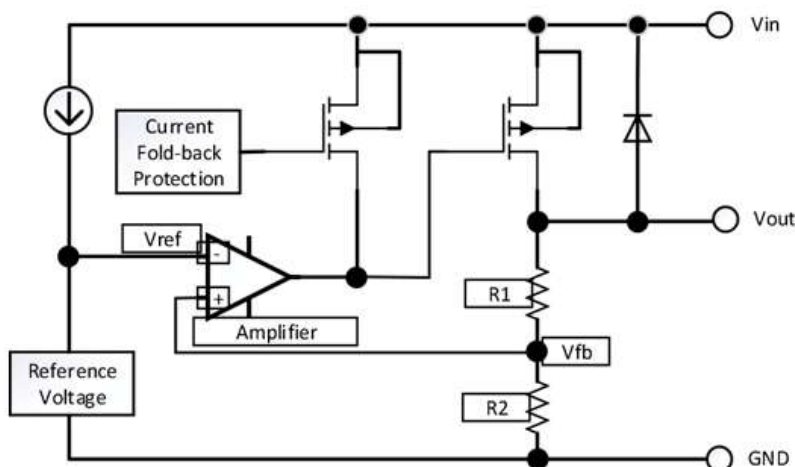

**Pin Assignment (TOP VIEW)**

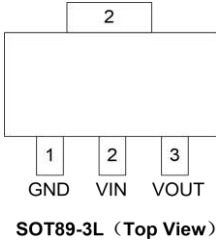
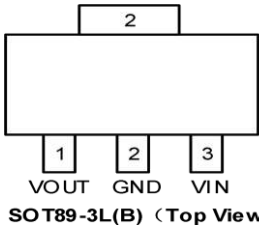
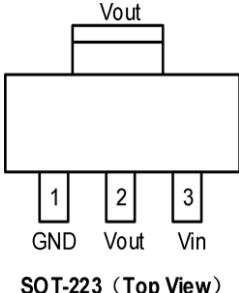
<b>CYP7903PxxPx</b>		
NO.	Description	 <p style="text-align: center;">SOT89-3L (Top View)</p>
1	GND	
2	VIN	
3	VOUT	
MARK	03Pxx YWH	
<b>CYP7903PxxPBx</b>		
NO.	Description	 <p style="text-align: center;">SOT89-3L(B) (Top View)</p>
1	VOUT	
2	GND	
3	VIN	
MARK	03PBxx YWH	
<b>CYP7903PxxFx</b>		
NO.	Description	 <p style="text-align: center;">SOT-223 (Top View)</p>
1	GND	
2	VIN	
3	VOUT	
MARK	03Fxx YWH	
<b>CYP7903PxxFBx</b>		
NO.	Description	
1	VOUT	
2	GND	

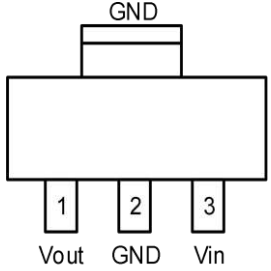
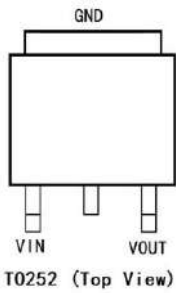
3	VIN	 <p style="text-align: center;"><b>SOT-223 (B) (Top View)</b></p>
MARK	03FBxx YWH	
<b>CYP7903PxxJx</b>		
NO.	Description	 <p style="text-align: center;"><b>T0252 (Top View)</b></p>
1	VOUT	
2	GND	
3	VIN	
MARK	03Jxx YWH	

Note: xx: Output Voltage, “33”stands for 3.3V

Y: The Year of manufacturing, “1” stands for year 2021;

W: The week of manufacturing. “20” stands for week 20;

H: Factory Code;

## Application Circuits

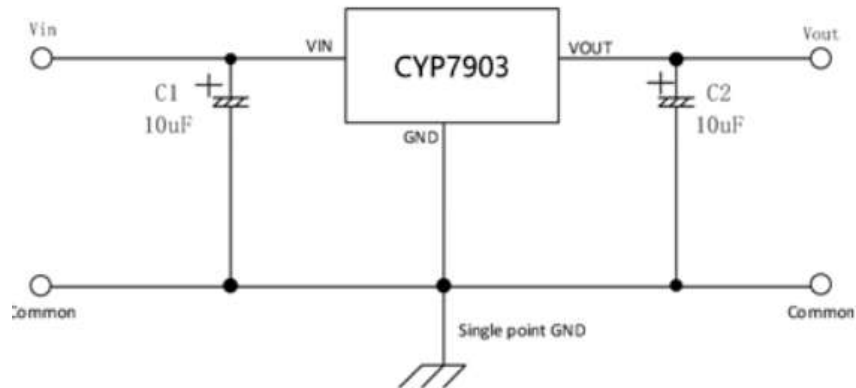



### Absolute Maximum Ratings

(Unless otherwise indicated:  $T_a=25^{\circ}\text{C}$ )

PARAMETER	SYMBOL	MIN	MAX	UNITS
Input Voltage	$V_{IN}$	-0.3	40	V
Output Voltage	$V_{OUT}$	$V_{SS}-0.3$	$V_{IN}+0.3V$	
Power Dissipation	PD (1)		SOT 89 1000 TO 252 1800 SOT 223 1500	mW
Operating Ambient Temperature	$T_{opr}$	-40	85	$^{\circ}\text{C}$
Storage Temperature	$T_{stg}$	-40	125	
ESD Protection	ESD HBM		2000	V

Note: These are just the limit parameters. Beyond the range specified in the Absolute Maximum Ratings may cause serious damage to the equipment. Long exposure to extreme conditions may affect the reliability of the device.

(1)Increasing the welding area of package is beneficial to increase power consumption

### Electrical Characteristics

CYP7903 Series (Unless otherwise indicated:  $T_a=25^{\circ}\text{C}$ )

PARAMETER	SYMBOL	CONDITIONS	MIN	TYP	MAX	UNIT	
Output Voltage <sup>1</sup>	$V_{OUT(S)}$	$V_{IN}=V_{OUT(S)}+2V, I_{OUT}=10\text{mA}$	$V_{OUT(S)} \times 0.98$	$V_{OUT(S)}$	$V_{OUT(S)} \times 1.02$	V	
Dropout Voltage <sup>2</sup>	$V_{DROP}$	$I_{OUT}=1\text{mA}$		4	8	mV	
		$I_{OUT}=1\text{A}$		1000	1500		
Line Regulation	$\frac{V_{OUT}}{V_{IN} - V_{OUT}}$	$V_{OUT(S)}+2V \leq V_{IN} \leq 40V$ $I_{OUT} = 1\text{mA}$		0.01	0.02	%/V	
Load Regulation	$\Delta V_{OUT2}$	$V_{IN}=V_{OUT(S)}+2V$ $1\text{mA} \leq I_{OUT} \leq 300\text{mA}$	$V_{OUT(S)} \leq 10V$	20	80	mV	
			$V_{OUT(S)} > 10V$	85	150		
Temperature Stability	$\frac{V_{OUT}}{T_a}$	$V_{IN} = V_{OUT(S)}+2V, I_{OUT}=10\text{mA}$ $-40^{\circ}\text{C} \leq T_a \leq 85^{\circ}\text{C}$		$\pm 50$		ppm/ $^{\circ}\text{C}$	
Quiescent Current	$I_q$	no load	$V_{OUT(S)} < 5.0V$	0.8	1.6	2	$\mu\text{A}$
			$V_{OUT(S)} \geq 5.0V$	1.5	3	3.6	
Input Voltage	$V_{IN}$	---	2.2		40	V	
Maximum Output Current	$I_{OUTMAX}$				1	A	
Current Limit <sup>3</sup>	$I_{LIM}$	$V_{IN}=V_{OUT(S)}+2V, V_{OUT} = 0.9 \times V_{OUT(S)}$		1.8		A	
Short Circuit Current	$I_{SHORT}$	$V_{IN}=V_{OUT(S)}+2V, V_{OUT}$ and GND is $0\Omega$		120		mA	



Power Supply Rejection Ratio	PSRR	f=10Hz, VOUT(S)=3.6V	73.2	dB
		f=100Hz, VOUT(S)=3.6V	72.2	
		f=1kHz, VOUT(S)=3.6V	54.5	
Over Temperature Protection	OTP	IOUT=10mA	145	°C

Notes:

1.  $V_{OUT(S)}$ : Output voltage when  $V_{IN} = V_{out} + 2V$ ,  $I_{out} = 1 \text{ mA}$ .
2.  $V_{DROP} = V_{in1} - (V_{out(S)} \times 0.98)$  where  $V_{in1}$  is the input voltage when  $V_{out} = V_{out(S)} \times 0.98$ .
3.  $I_{LIM}$ : Output current when  $V_{in} = V_{out(S)} + 2V$  and  $V_{out} = 0.95 * V_{out(S)}$ .

### Typical Performance Characteristics

Test Conditions: CYP7903P36  $C_{IN} = 4.7\mu F$ ,  $C_{OUT} = 4.7\mu F$ , unless otherwise indicated.

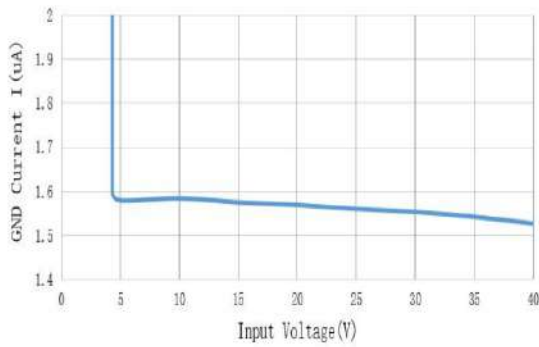

GND Current vs Input Voltage  
CYP7903P36

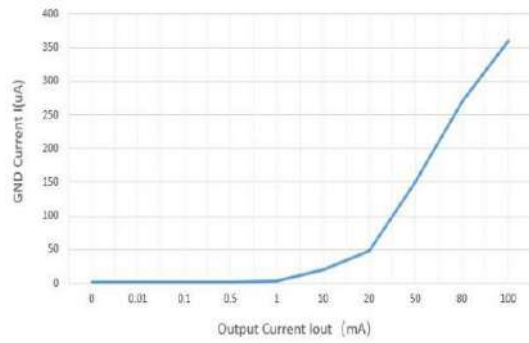

GND Current vs Output Current  
CYP7903P36

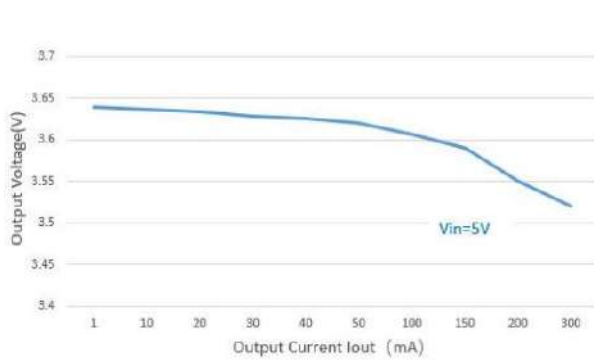

VOUT vs Current out  
CYP7903P36

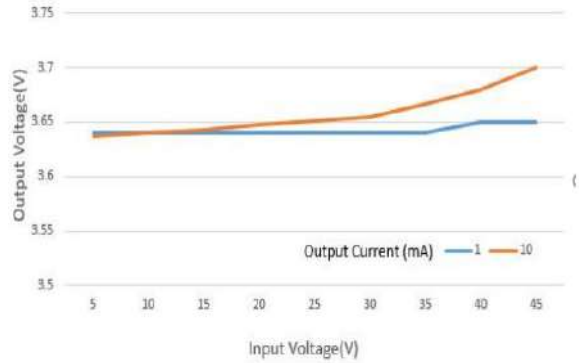

VOUT vs Input Voltage  
CYP7903P36

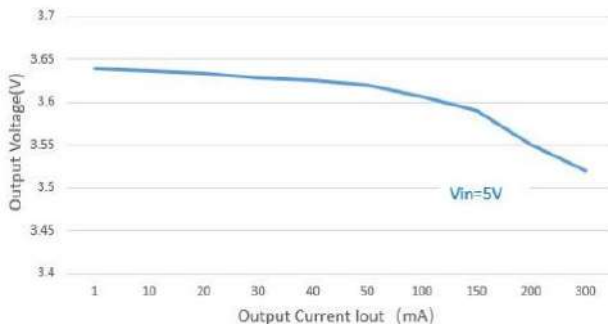

VOUT vs Current out  
CYP7903P36

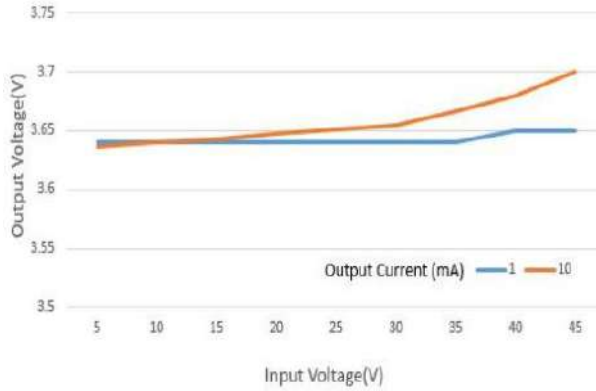

VOUT vs Input Voltage  
CYP7903P36



### Typical Performance Characteristics

Test Conditions:  $V_{IN}=V_{OUT}+2.0V$ ,  $C_{IN}=2.2\mu F$ ,  $C_{OUT}=2.2\mu F$ , unless otherwise indicated.

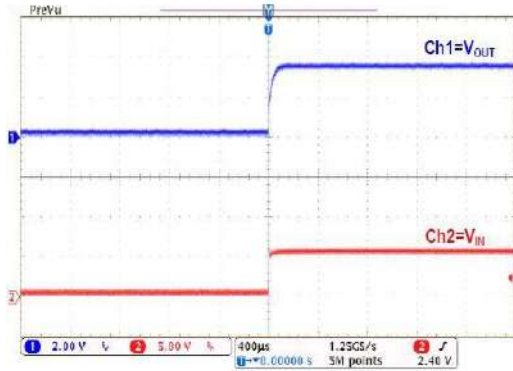

Power-Up at  $V_{OUT}=3.6V$   
CYP7903P36( $I_{OUT}=0mA$ )

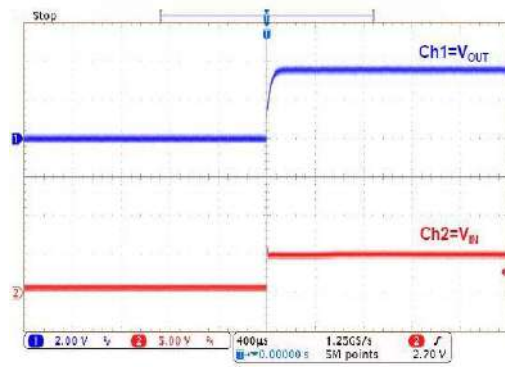

Power-Up at  $V_{OUT}=3.6V$   
CYP7903P36( $I_{OUT}=1A$ )

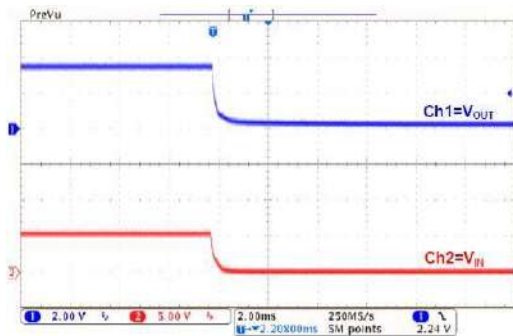

Power- Down at  $V_{OUT}=3.6V$   
CYP7903P36( $I_{OUT}=0mA$ )

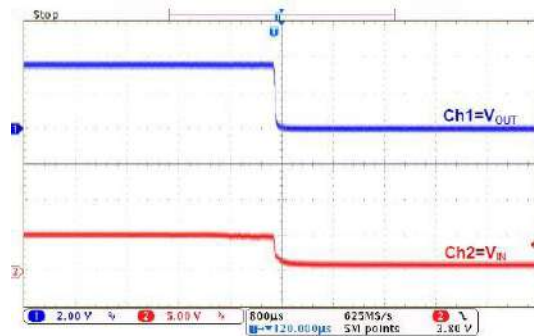

Power- Down at  $V_{OUT}=3.6V$   
CYP7903P36( $I_{OUT}=1A$ )

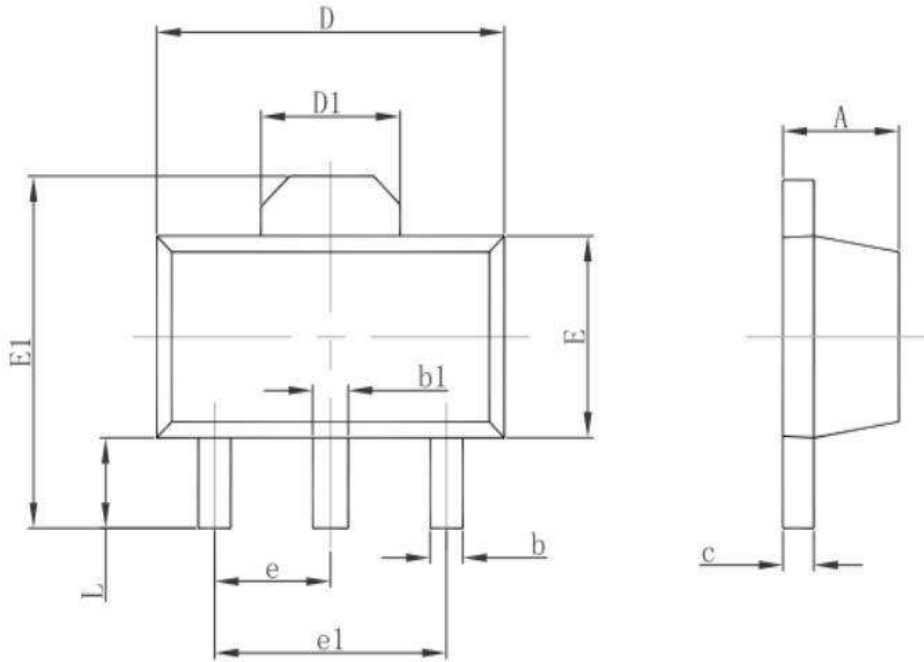

**Package Information**
**SOT89-3L Package Outline Dimensions**

Symbol	Dimensions In Millimeters		Dimensions In Inches	
	Min	Max	Min	Max
A	1.400	1.600	0.055	0.063
b	0.320	0.520	0.013	0.020
b1	0.400	0.580	0.016	0.023
c	0.350	0.440	0.014	0.017
D	4.400	4.600	0.173	0.181
D1	1.550 REF		0.061 REF	
E	2.300	2.600	0.091	0.102
E1	3.940	4.250	0.155	0.167
e	1.500 TYP		0.060 TYP	
e1	3.000 TYP		0.118 TYP	
L	0.900	1.200	0.035	0.047

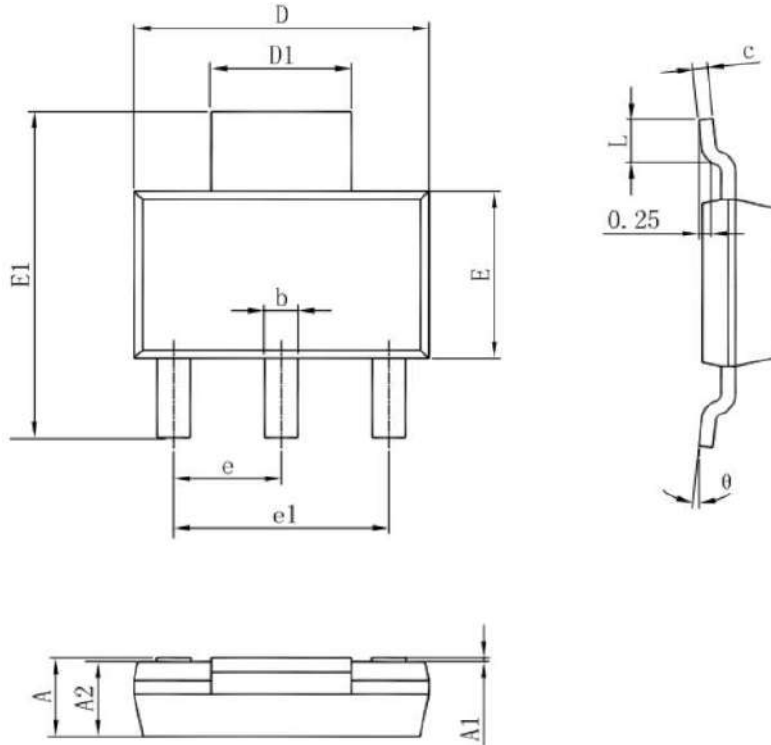
**SOT223 Package Outline Dimensions**

Symbol	Dimensions In Millimeters		Dimensions In Inches	
	Min	Max	Min	Max
A	1.520	1.800	0.060	0.071
A1	0.000	0.100	0.000	0.004
A2	1.500	1.700	0.059	0.067
b	0.660	0.820	0.026	0.032
c	0.250	0.350	0.010	0.014
D	6.200	6.400	0.244	0.252
D1	2.900	3.100	0.114	0.122
E	3.300	3.700	0.130	0.146
E1	6.830	7.070	0.269	0.278
e	2.300(BSC)		0.091(BSC)	
e1	4.500	4.700	0.177	0.185
L	0.900	1.150	0.035	0.045
θ	0°	10°	0°	10°

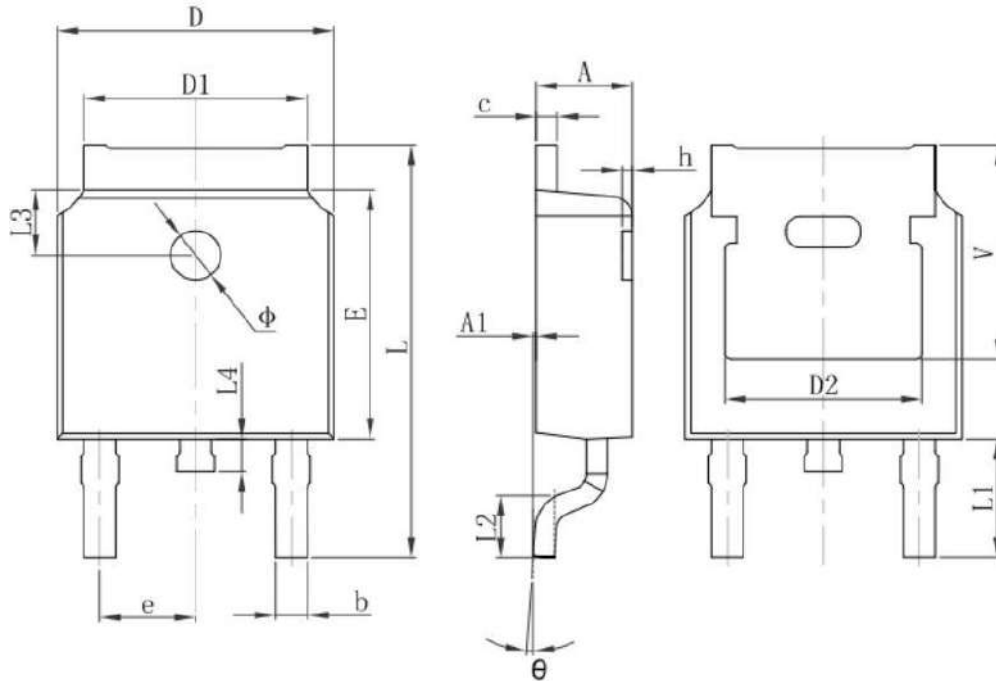
**TO252 Package Outline Dimensions**

Symbol	Dimensions In Millimeters		Dimensions In Inches	
	Min	Max	Min	Max
A	2.200	2.400	0.087	0.094
A1	0.000	0.127	0.000	0.005
b	0.660	0.860	0.026	0.034
c	0.460	0.580	0.018	0.023
D	6.500	6.700	0.256	0.264
D1	5.100	5.460	0.201	0.215
D2	4.830 REF		0.190 REF	
E	6.000	6.200	0.236	0.244
e	2.186	2.386	0.086	0.094
L	9.800	10.400	0.386	0.409
L1	2.900 REF		0.114 REF	
L2	1.400	1.700	0.055	0.067
L3	1.600 REF		0.063 REF	
L4	0.600	1.000	0.024	0.039
Φ	1.100	1.300	0.043	0.051
θ	0°	8°	0°	8°
h	0.000	0.300	0.000	0.012
V	5.350 REF		0.211 REF	



## Special Version

The company reserves the right of final interpretation of this specification.

### Version Change Description

Versions: V1.2	Writer: Si Yuan Wu	Time: 2021.10.29
Modify the record: 1. Re-typesetting the manual and checking some data		
Versions: V1.3	Writer: Yang Yang	Time: 2022.2.11
Modify the record: 1. Update quiescent current data for different output voltages		
V1.4	Writer: Yang Yang	Time: 2022.6.15
Modify the record: 1.Add the SOT89(B) and SOT223(B) package pin diagram		
V1.5	Writer: Yang Yang	Time: 2022.7.4
Modify the record: 1.Update the SOT223 package pin diagram		

### The statement

The information in the usage specification is correct at the time of publication. CY Wireless Technology Limited has the right to change and interpret the specification, and reserves the right to modify the product without prior notice. Users can obtain the latest version information from our official website or other effective channels before confirmation, and verify whether the relevant information is complete and up to date.

With any semiconductor product, there is a certain possibility of failure or failure under certain conditions. The buyer is responsible for complying with safety standards and taking safety measures when using the product for system design and complete machine manufacturing. The product is not authorized to be used as a critical component in life-saving or life-sustaining products or systems, in order to avoid potential failure risks that may cause personal injury or property loss.