

60V, 500mA, DCDC Step-Down Converter

CYP9459

General Description

The CYP9459 is a monolithic, step-down, switch-mode converter with a built-in power MOSFET. It achieves a 0.5A peak-output current over a wide input supply range with excellent load and line regulation. Current-mode operation provides a fast transient response and eases loop stabilization.

The wide input range (4.5V to 60V) provides high efficiency output of 0.5A current, Low shutdown mode quiescent current of 0.1 μ A is suitable for battery-powered applications.

Fault condition protections include cycle-by-cycle current limiting and thermal shutdown.

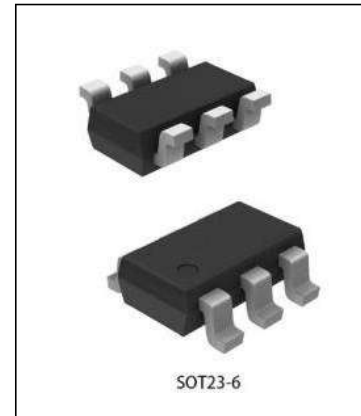

Features

- Output 0.5A peak current
- 4.5V to 60 V operating input range
- 1 Ω internal power MOSFET
- 480KHz fixed switching frequency
- Stable with Low-ESR Ceramic Output Capacitors
- Cycle-by-Cycle Over-Current Protection
- Thermal shutdown protection
- >90% efficiency
- Output voltage: adjustable from +0.81V to 0.95V_{in}
- Low shutdown mode current: <1 μ A
- SOT23-6 package

Applications

- High voltage power conversion
- Industrial power system
- Distributed power system
- Battery powered system

Order specification

Part No	Package	Manner of Packing	Devices per bag/reel
CYP9459	SOT23-6	Reel	3000

Block Diagram and Pin Arrangement Diagram

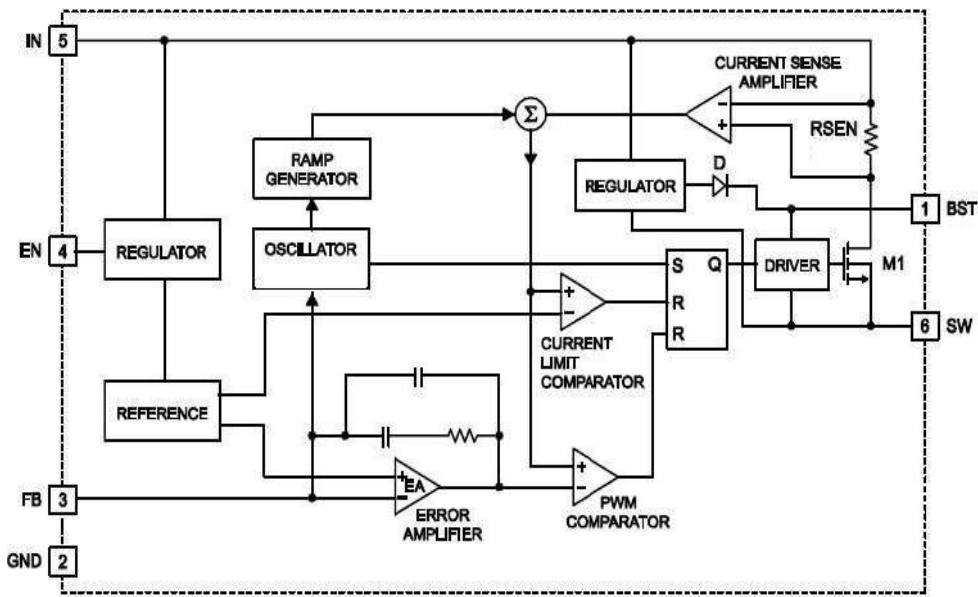

Pin Assignment

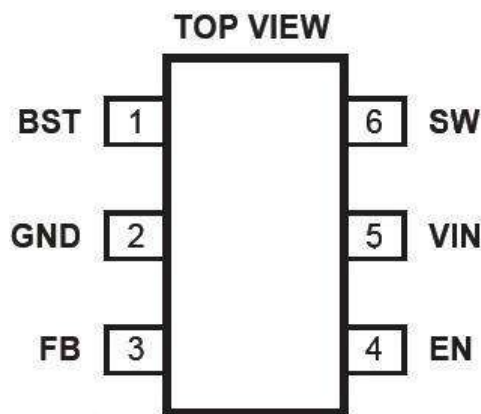



Pin No.	Pin Name	Description
1	BST	Bootstrap. This is the positive power supply for the internal floating high side MOSFET driver. Connect a bypass capacitor between this pin and SW pin.
2	GND	Ground. It should be connected as close as possible to the output capacitor, avoid high current switching paths.
3	FB	Feedback. Sets the output voltage. Connect to the tap of an external resistor divider from the output to GND. The frequency foldback comparator lowers the oscillator frequency when the FB voltage is below 250mV to prevent current-limit runaway during a short-circuit fault.
4	EN	Enable input. Pull this pin below the specified threshold to disable. Pull it above the specified threshold to enable. Connect 100K resistor to IN, it can be turned on automatically.
5	VIN	Input Supply. All internal control circuits are powered. A decoupling capacitor to ground is required close to this pin to reduce switching spikes.
6	SW	Switch output

Absolute Maximum Ratings

Parameter	Symbol	Min.	Max.	Unit
Supply Voltage	V _{IN}	-0.3	62	V
Switch Voltage	V _{SW}	-0.3	V _{IN(MAX)} +0.3	V
BST to SW		-0.3	6.0	V
All Other Pins		-0.3	6.0	V
Continuous Power Dissipation(TA=+25°C)	P _D		0.568	W
Junction Temperature	T		150	°C
Lead Temperature	T		260	°C
Storage Temperature	T _{STG}	-65	150	°C
Operating Junction Temp	T _J	-40	125	°C
Junction-to-Ambient Thermal Resistance	θ _{JA}		220	°C/W
Junction-to-Case Thermal Resistance	θ _{JC}		110	°C/W

Exceeding these ratings may damage the device.

Recommended Operating Conditions

Parameter	Symbol	Min.	Max.	Unit
Supply Voltage	V _{IN}	4.5	60	V
Output Voltage	V _{OUT}	0.81	0.95*V _{IN}	V
Operating Temperature	T	-40	85	°C

Electrical Characteristics

$V_{in}=12V, T_{amb}= 25^{\circ}C$, unless specified otherwise.

Parameter	Symbol	Test Conditions	Min	Typ	Max	Unit
Feedback Voltage	Vfb		0.792	0.812	0.832	V
Upper Switch ON Resistance	Rsw	$V_{bst}-V_{sw}=5V$		1		Ω
Upper Switch Leakage	Iswleak	$V_{en}=0V, V_{sw}=0V$			1	μA
Limiting Current	Ilim		1.0	1.25	1.5	A
Oscillator Frequency	Fosc		380	480	580	KHz
Turn-back frequency	Fsw-f	$V_{fb}=0V$		150		KHz
Under-voltage on voltage	Vuvlo-r		2.9	3.3	3.73	V
Under-voltage lockout	Vuvlo-f		2.65	3.05	3.45	V
Minimum Switch ON Time	Ton min			100		ns
Enable on voltage	Venr			1.35		V
Enable off voltage	Venf			1.17		V
EN input current	Ien	$V_{en}=2V$		3.1		μA
		$V_{en}=0V$		0.1		μA
Quiescent Current	Iq	$V_{en}=2V, V_{fb}=1V$		0.73	0.86	mA
Shutdown Current	Is	$V_{en}=0V$		0.1	1.0	μA
Thermal Shutdown	Tsd			165		$^{\circ}C$

Detailed Description

The CYP9459 is a 480KHz, step-down switching regulator with integrated internal high side MOSFET. The output of the circuit's internal amplifier is proportional to the peak inductance current, and the feedback signal is compared with the internal 0.812V reference voltage to stabilize the output voltage. It has a wide input voltage range, precise current limit, low operational quiescent current feature is suit for battery powered applications.

Application Circuits

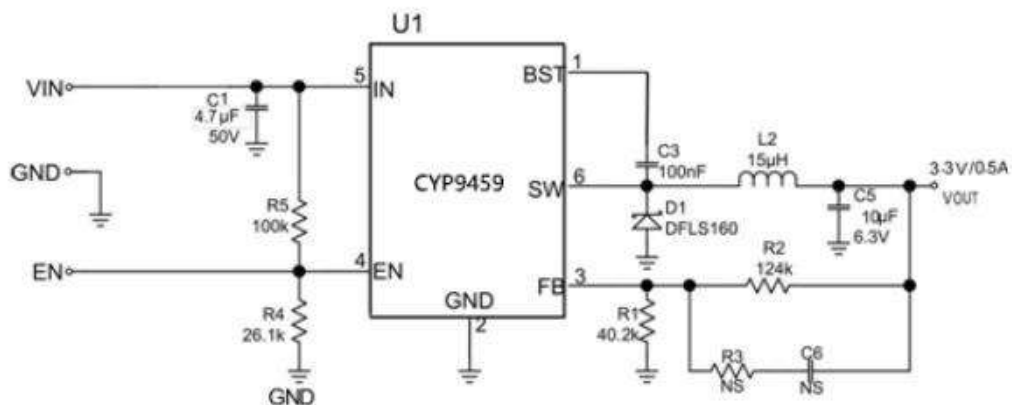

**PCB layout reference:**

PCB layout is very important for the circuit to achieve stable operation. The following suggestions are for your reference:

1. Keep the path of switching current short and minimize the loop area formed by the input capacitor, high-side MOSFET, and Schottky diode.
2. Bypass ceramic capacitor is placed near the Vin pin. Keep the connection from the power ground→Schottky diode→SW pin as short and wide as possible.
3. All feedback circuit connections should be short and direct, with feedback resistance and compensation elements as close to the chip as possible.
4. SW route should be far away from sensitive simulated areas, such as FB.
5. SW, IN, and especially ground should be connected to a large copper-clad area to cool the chip, improve thermal performance, and enhance long-term reliability.

Application recommendation: Select components**Setting the Output Voltage**

The output voltage is set using a resistive voltage divider from the output voltage to FB pin. $V_{FB} = V_{OUT} * R1 / (R1 + R2)$

Reference resistance for each output voltage:

Vout (V)	R1(KΩ)	R2(KΩ)
1.8	64.9 (1%)	80.6 (1%)
2.5	23.7 (1%)	49.9 (1%)
3.3	16.2 (1%)	49.9 (1%)
5	9.53 (1%)	49.9 (1%)

Inductor

The inductor is required to supply constant current to the output load. A larger value inductor will result in lower output ripple voltage. However, the volume will be larger, large series resistance and low saturation current.

Generally, a good rule for determining the inductance to use is to allow the peak-to-peak ripple current in the inductor to be approximately 30% of the maximum load current. Also, make sure that the peak inductor current is below the maximum switch current limit. It will not saturate at the maximum inductance peak. L1 can be calculated according to the following formula:

$$L1 = \frac{V_{OUT}}{f_S \times \Delta I_L} \times \left(1 - \frac{V_{OUT}}{V_{IN}} \right)$$



Input Capacitor

The input capacitor can be electrolytic, tantalum or ceramic. When using electrolytic or tantalum capacitors, a small, high quality ceramic capacitor, i.e. 0.1 μ F, should be placed as close to the IC as possible. When using ceramic capacitors, make sure they have sufficient capacitance values to prevent input from excessive voltage ripple.

Output Capacitor

The output capacitor is used to maintain the DC output voltage. Low ESR electrolytic capacitors are recommended to keep the output voltage ripple low. The characteristics of the output capacitor will affect the stability of the voltage stabilizer system.

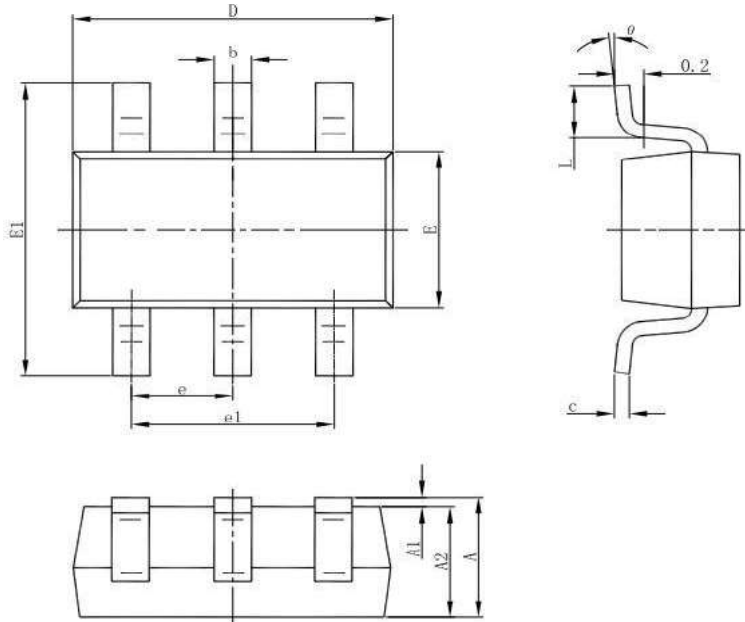
Package Information (SOT23-6)

Symbol	Dimensions In Millimeters		Dimensions In Inches	
	Min.	Max.	Min.	Max.
A	1.050	1.250	0.041	0.049
A1	0.000	0.100	0.000	0.004
A2	1.050	1.150	0.041	0.045
b	0.300	0.500	0.012	0.020
c	0.100	0.200	0.004	0.008
D	2.820	3.020	0.111	0.119
E	1.500	1.700	0.059	0.067
E1	2.650	2.950	0.104	0.116
e	0.950(BSC)		0.037(BSC)	
e1	1.800	2.000	0.071	0.079
L	0.300	0.600	0.012	0.024
θ	0°	8°	0°	8°



Special Instructions

The company reserves the right of final interpretation of this specification.

Version Change Description

Version: V1.4

Author: YY

Time: 2021.10.15

Modify the record:

1. Re-typesetting the manual and checking some data
-

Statement

The information in the usage specification is correct at the time of publication. CY Wireless Technology Limited has the right to change and interpret the specification, and reserves the right to modify the product without prior notice. Users can obtain the latest version information from our official website or other effective channels before confirmation, and verify whether the relevant information is complete and up to date.

With any semiconductor product, there is a certain possibility of failure or failure under certain conditions. The buyer is responsible for complying with safety standards and taking safety measures when using the product for system design and complete machine manufacturing. The product is not authorized to be used as a critical component in life-saving or life-sustaining products or systems, in order to avoid potential failure risks that may cause personal injury or property loss.