



# 300mA、8V、Low Power LDO

## CYP6216

### General Description

CYP6216 series are a highly precise, lower consumption, 3 terminal, positive voltage regulators manufactured using CMOS and laser trimming technologies. The series provides large currents with a significantly small dropout voltage .

The CYP6216 consists of a current limiter circuit, a driver transistor, a precision reference voltage and an error correction circuit. The series is compatible with low ESR ceramic capacitors. The current limiter's foldback circuit operates as a short circuit protection as well as the output current limiter for the output pin. Output voltages are internally by laser trimming technologies. It is selectable in 0.1V increments within a range of 1.5V to 3.6V. CYP6216 series are available in SOT-23,SOT23-3 and SOT89 packages.



### Features

- Low power consumption
- Low voltage drop
- Low temperature coefficient
- Low Quiescent Current: 5 $\mu$ A @ 6V
- Output voltage accuracy: tolerance  $\pm 2\%$

### Applications

- Battery-powered equipment
- Reference voltage sources
- Cameras, video cameras
- Portable AV systems
- Mobile phones
- Portable games

### Order information

Device	Package	Packaging style	SPQ
CYP6216-XXNX	SOT23	Reel	3000
CYP6216-XXMX	SOT23-3	Reel	3000
CYP6216-XXPX	SOT89	Reel	1000

## Order Information

CYP6216-①②③④

Designator	Symbol	Description
①②	Integer	Output Voltage(1.5V~3.6V)
③	N	Package:SOT23
	M	Package:SOT23-3
	P	Package:SOT89
④	R	RoHS / Pb Free
	G	Halogen Free

Note: "①②" stands for output voltages. Other voltages can be specially customized.

## Marking Rule

Part No	Marking			
	(1)	(2)	(3)	(4)
CYP6216-15YR	6	5	E	9
CYP6216-18YR	6	5	K	5
CYP6216-25YR	6	5	T	5
CYP6216-28YR	6	4	F	K
CYP6216-30YR	6	5	Z	5
CYP6216-33YR	6	6	2	K
CYP6216-36YR	6	6	5	K

Note: Y: Representative product packaging

## Block Diagram

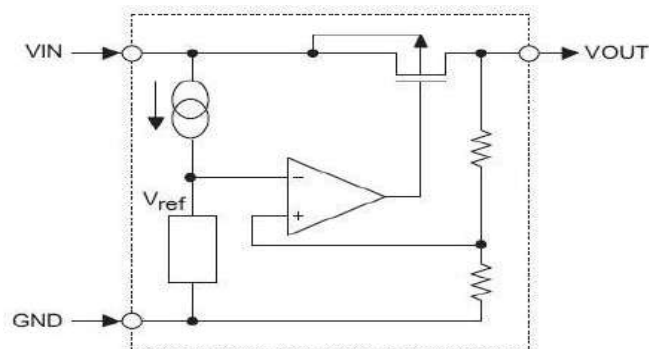

## Pin Assignment

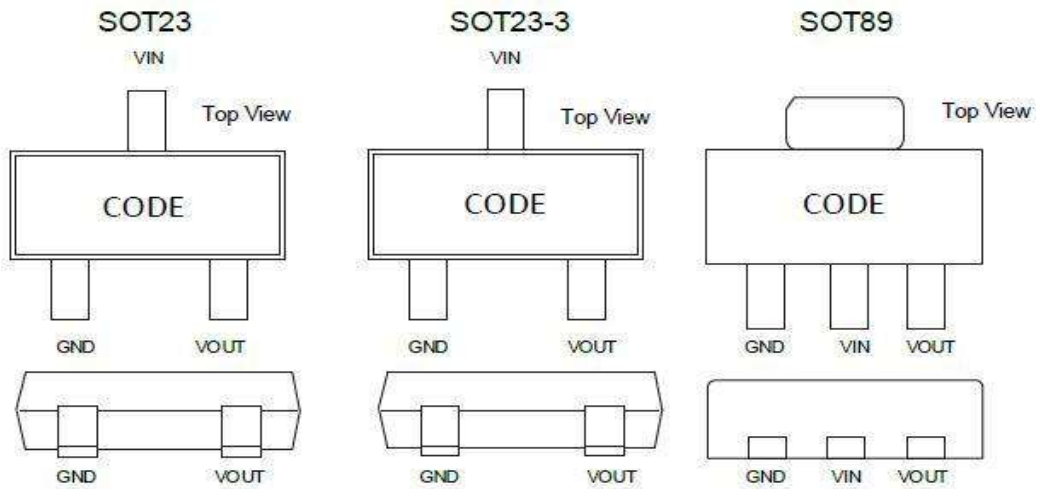

## Typical Application

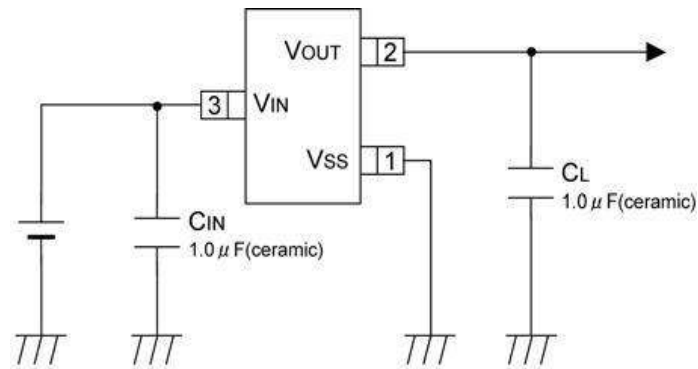

## Absolute Maximum Ratings

Parameter	Symbol	Ratings	Units	
Input Voltage	$V_{IN}$	8	V	
Output Current	$I_{OUT}$	300*	mA	
Output Voltage	$V_{OUT}$	$V_{SS}-0.3 \sim V_{IN}+0.3$	V	
Power Dissipation	SOT-23	$P_d$	0.20	W
	SOT23-3		0.25	W
	SOT89		0.50	W
Operating Temperature Range	$T_{opr}$	-40~+85	°C	
Storage Temperature Range	$T_{stg}$	-55~+125	°C	

\*  $I_{OUT} = P_d / (V_{IN} - V_{OUT})$



## Electrical Characteristics

CYP6216 for any output voltage

(Ta=25°C)

Parameter	Symbol	Conditions	Min.	Typ.	Max.	Unit
Output Voltage	V <sub>out</sub>	V <sub>in</sub> =V <sub>out</sub> +1V 1.0mA≤I <sub>out</sub> ≤30mA	V <sub>out</sub> ×0.98	--	V <sub>out</sub> ×1.02	V
Output Current	I <sub>out</sub>	V <sub>in</sub> -V <sub>out</sub> =1V	--	300	--	mA
Low dropout	V <sub>drop</sub>	Refer to the next table				
Line Regulation	$\Delta V_{out}/\Delta V_{in} \cdot V_{out}$	1.6V≤V <sub>in</sub> ≤8V I <sub>out</sub> =40mA	--	0.1	0.2	%/V
Load Regulation	$\Delta V_{out}/\Delta I_{out}$	V <sub>in</sub> =V <sub>out</sub> +1V 1.0mA≤I <sub>out</sub> ≤80mA	--	12	30	mV
Output voltage Temperature Coefficiency	$\Delta V_{out}/(T_a \cdot V_{out})$	I <sub>out</sub> =30mA 0°C≤T <sub>a</sub> ≤70°C	--	±100	--	ppm/°C
Supply Current	I <sub>ss1</sub>	--	--	5	10	μA
Input Voltage	V <sub>in</sub>	--	--	6	8	V
PSRR	PSRR	F=1KHz V <sub>in</sub> =V <sub>out</sub> +1V	--	50	--	dB

Electrical Characteristics by Output Voltage:

Output Voltage V <sub>out</sub> (V)	Dropout Voltage V <sub>dif</sub> (V)		
	Conditions	Typ.	Max.
V <sub>out</sub> ≤1.5V	I <sub>out</sub> =100 mA	0.5	0.68
1.8 ≤ V <sub>out</sub> ≤ 2		0.39	0.53
2.8 ≤ V <sub>out</sub> ≤ 5.0		0.23	0.39



### Typical Performance Characteristics

Test Conditions: CYP621630NR  $C_{IN}=1\mu F$ ,  $C_{OUT}=1\mu F$ ,  $T_a=25^\circ C$ , unless otherwise indicated.

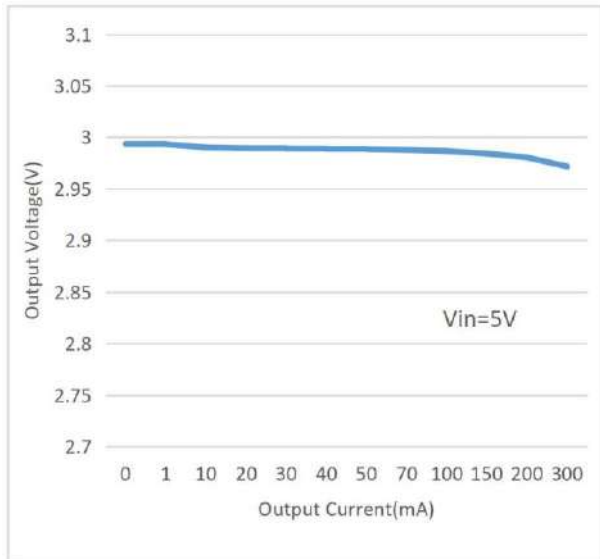

V<sub>OUT</sub> Vs Output Current  
CYP6216-30NR

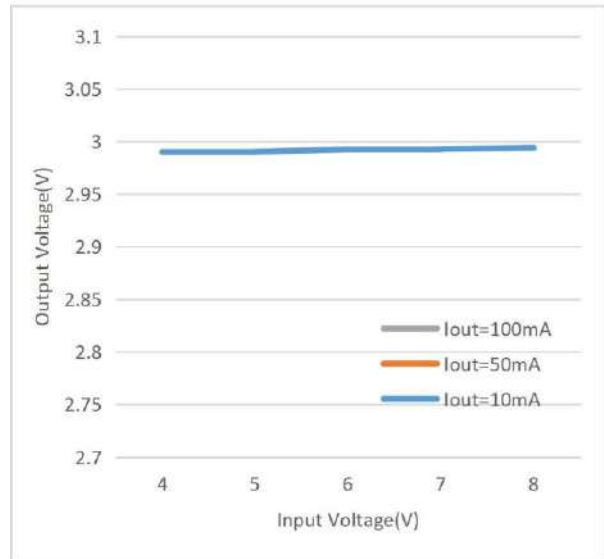

V<sub>OUT</sub> Vs Input Voltage  
CYP6216-30NR

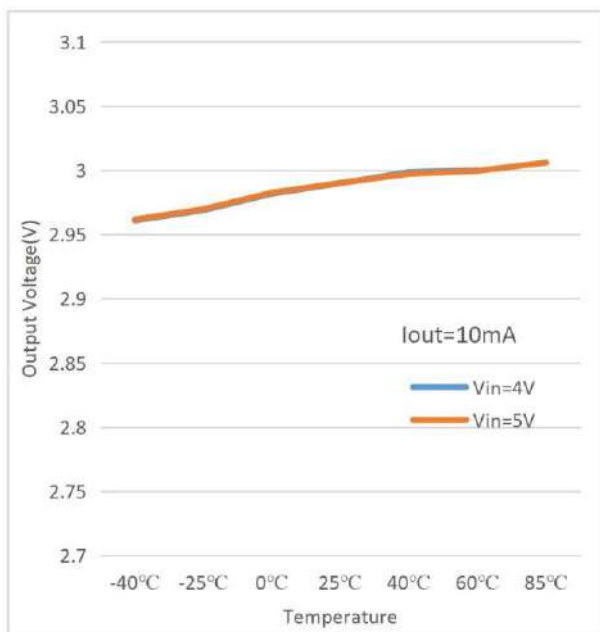

V<sub>OUT</sub> vs Temperature  
CYP6216-30NR

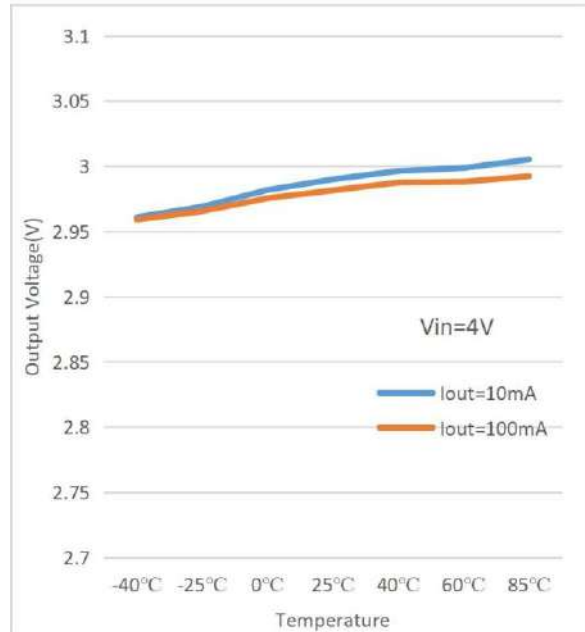

V<sub>OUT</sub> vs Temperature  
CYP6216-30NR



### Typical Performance Characteristics

Test Conditions: CYP621630NR  $V_{in}=V_{out}+2V$ ,  $C_{IN}=1\mu F$ ,  $C_{OUT}=1\mu F$ ,  $T_a=25^\circ C$ , unless otherwise indicated.

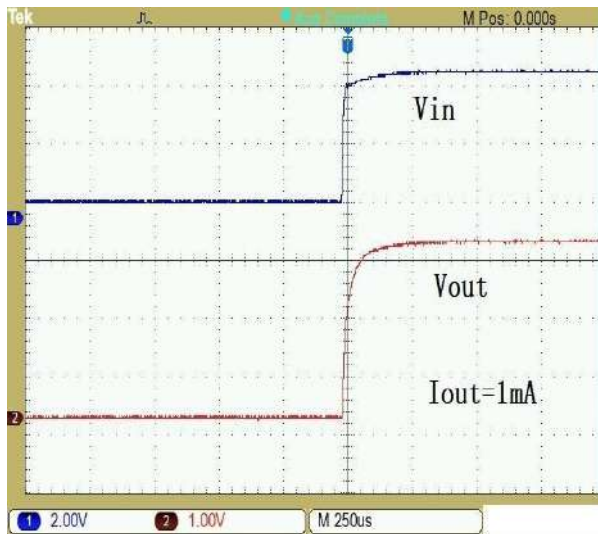

Power-Up at  $V_{OUT}=3.0V$  Time(250 $\mu s$ /div)  
( $V_{in}=5V, I_{OUT}=1mA$ )

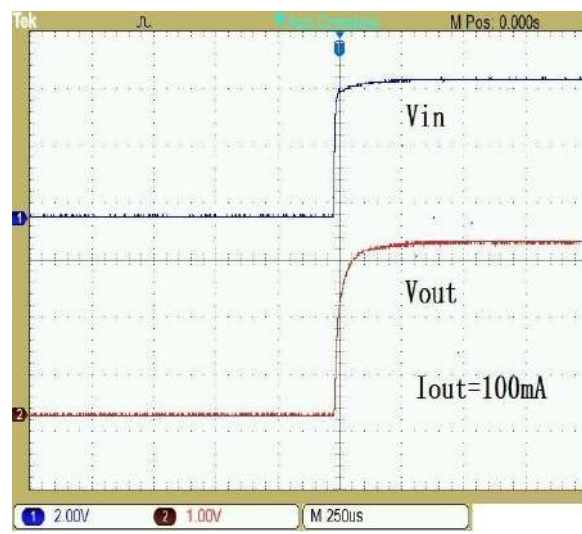

Power-Up at  $V_{OUT}=3.0V$  Time(250 $\mu s$ /div)  
( $V_{in}=5V, I_{OUT}=100mA$ )

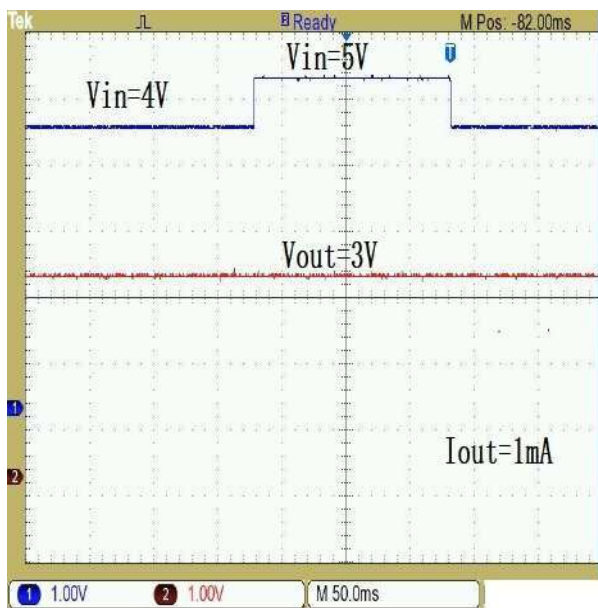

Input Voltage transient response  
( $V_{out}=3.0V, I_{out}=1mA$ )

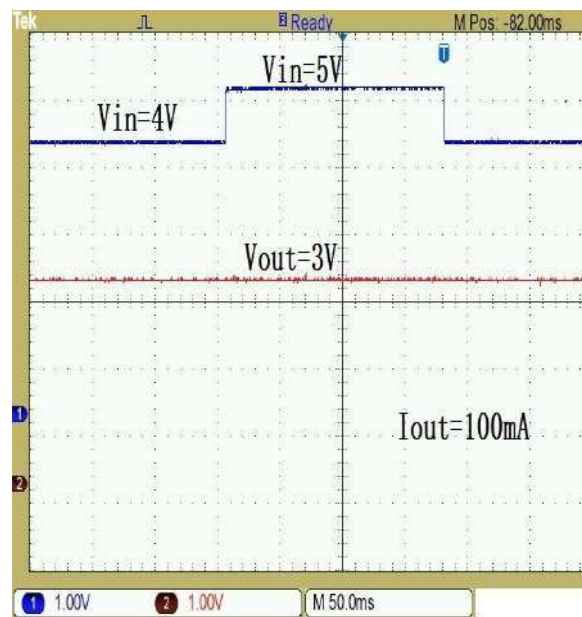

Input Voltage transient response  
( $V_{out}=3.0V, I_{out}=100mA$ )

## Package Information

### 3-pin SOT23 Outline Dimensions

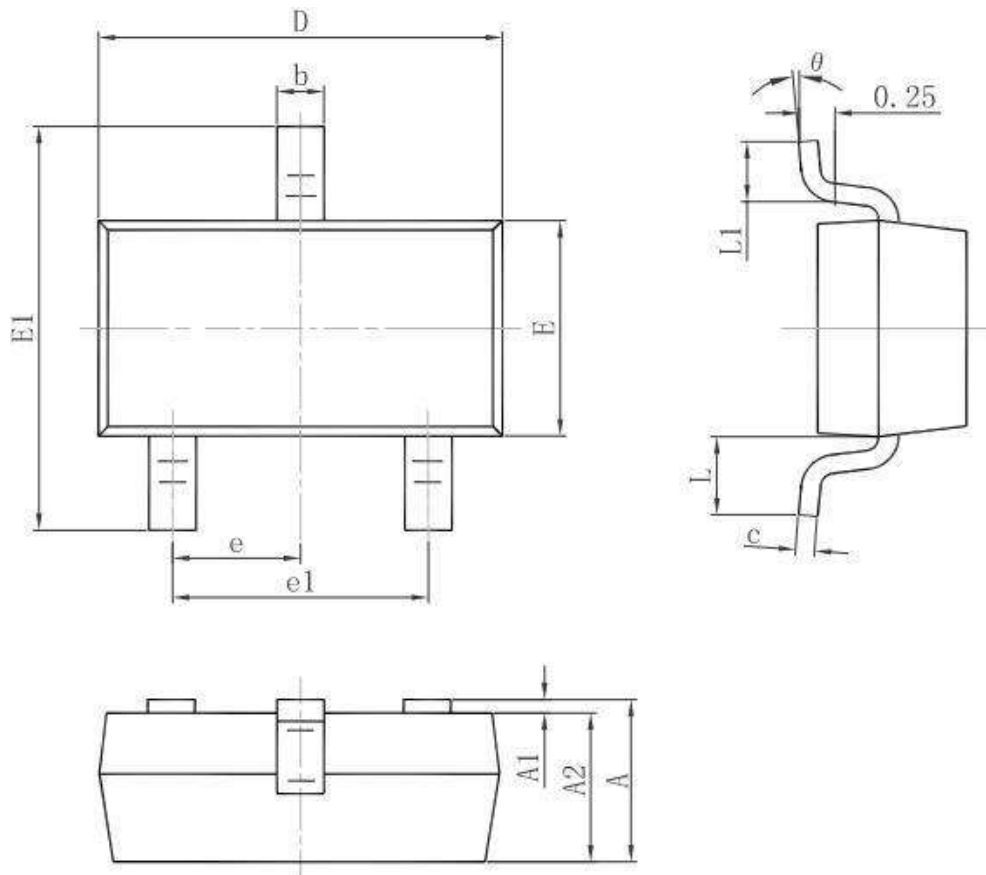

Symbol	Dimensions In Millimeters		Dimensions In Inches	
	Min.	Max.	Min.	Max.
A	0.900	1.150	0.035	0.045
A1	0.000	0.100	0.000	0.004
A2	0.900	1.050	0.035	0.041
b	0.300	0.500	0.012	0.020
c	0.080	0.150	0.003	0.006
D	2.800	3.000	0.110	0.118
E	1.200	1.400	0.047	0.055
E1	2.250	2.550	0.089	0.100
e	0.950 TYP.		0.037 TYP.	
e1	1.800	2.000	0.071	0.079
L	0.550 REF.		0.022 REF.	
L1	0.300	0.500	0.012	0.020
θ	0°	8°	0°	8°



3-pin SOT23-3 Outline Dimensions

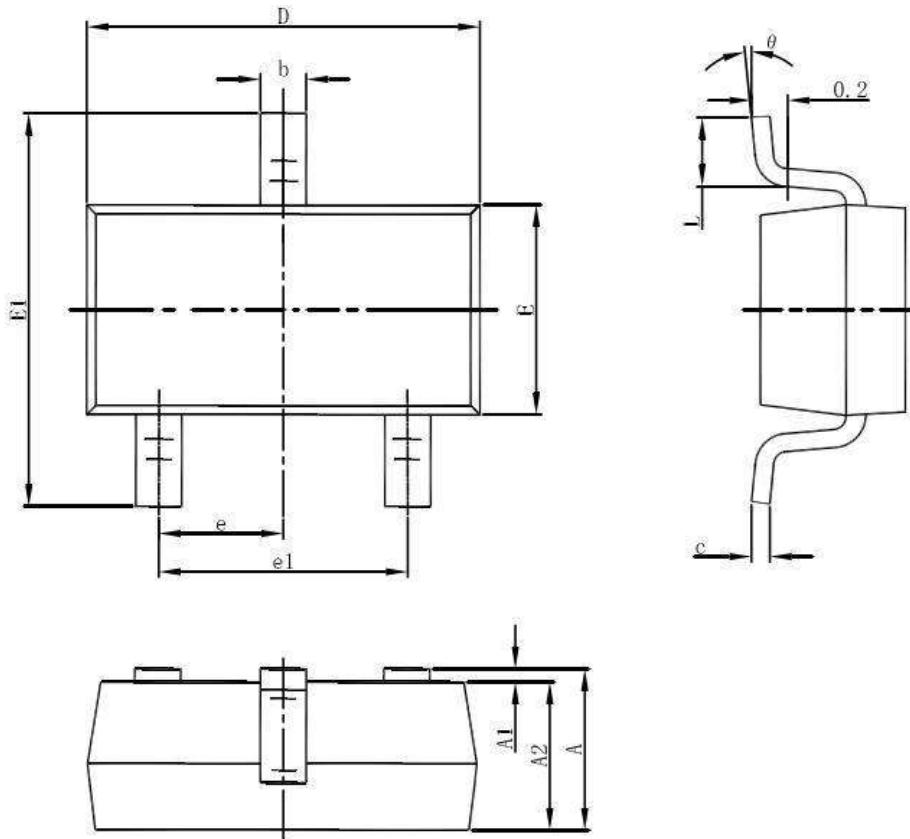

Symbol	Dimensions In Millimeters		Dimensions In Inches	
	Min	Max	Min	Max
A	1.050	1.250	0.041	0.049
A1	0.000	0.100	0.000	0.004
A2	1.050	1.150	0.041	0.045
b	0.300	0.500	0.012	0.020
c	0.100	0.200	0.004	0.008
D	2.820	3.020	0.111	0.119
E	1.500	1.700	0.059	0.067
E1	2.650	2.950	0.104	0.116
e	0.950(BSC)		0.037(BSC)	
e1	1.800	2.000	0.071	0.079
L	0.300	0.600	0.012	0.024
theta	0°	8°	0°	8°

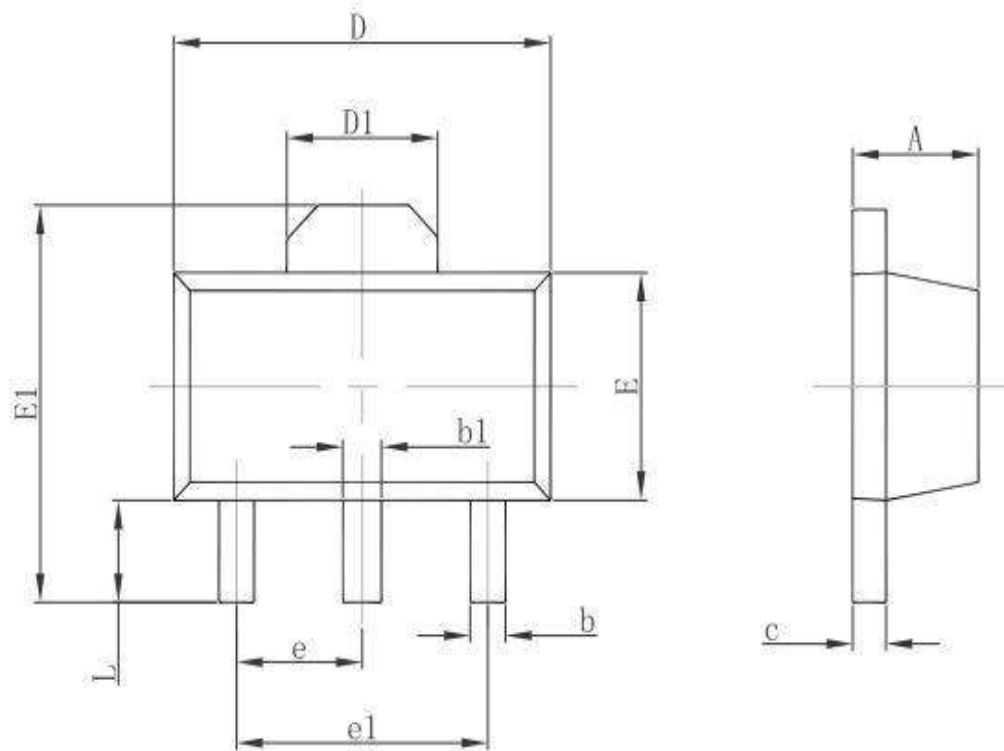

**3-pin SOT89 Outline Dimensions**

Symbol	Dimensions In Millimeters		Dimensions In Inches	
	Min.	Max.	Min.	Max.
A	1.400	1.600	0.055	0.063
b	0.320	0.520	0.013	0.020
b1	0.400	0.580	0.016	0.023
c	0.350	0.440	0.014	0.017
D	4.400	4.600	0.173	0.181
D1	1.550 REF.		0.061 REF.	
E	2.300	2.600	0.091	0.102
E1	3.940	4.250	0.155	0.167
e	1.500 TYP.		0.060 TYP.	
e1	3.000 TYP.		0.118 TYP.	
L	0.900	1.200	0.035	0.047



## **Special Version**

The company reserves the right of final interpretation of this specification.

## **Version Change Description**

---

Versions: V1.0

Writer: Xin CHun Li

Time: 2022.10.15

Amendant record:

1. Original Version