

500mA Low Power 15V Input Voltage LDO

CY78XX-1

General Description

The CY78XX-1 series is a group of positive voltage output, three-pin regulators, that provide a high current even when the input/output voltage differential is small. Low power consumption and high accuracy is achieved through CMOS and laser trimming technologies.

The CY78XX-1 consists of a high-precision voltage reference, an error amplification circuit, and a current limited output driver. Transient response to load variations have improved in comparison to the existing series. SOT89-3, SOT23-3 and SOT23-5 packages are available.

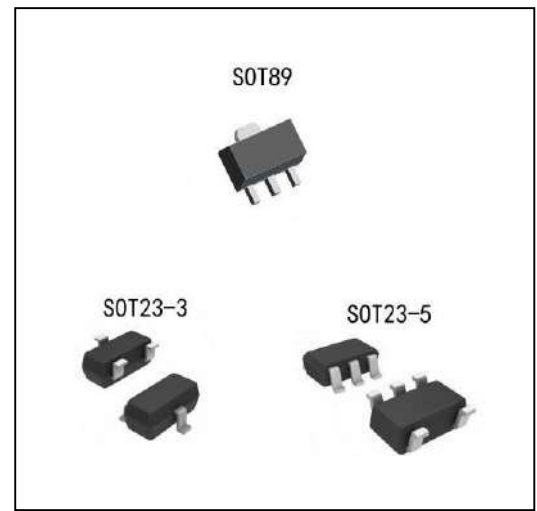

Features

- Low voltage drop: 0.17V@100mA
- Low Quiescent Current: 1.0uA
- High input voltage: 15V
- Low temperature coefficient
- Large Output Current: >0.5A
- Output voltage accuracy: tolerance $\pm 2\%$
- Built-in current limiter
- SOT89, SOT23-3 and SOT23-5 packages

Applications

- Battery-powered equipment
- Hand-Hold Equipment
- GRS Receivers
- Wireless LAN

**Order specification**

Part No	Package	Manner of Packing	Devices per bag/reel
CY78XX-1PX	SOT89	Reel	1000PCS/reel
CY78XX-1MX	SOT23-3	Reel	3000PCS/reel
CY78XX-1M5X	SOT23-5	Reel	3000PCS/reel

Description of selection

Part No	Output Voltage	Output Voltage Accuracy
CY7828-1XX	2.8V	±2%
CY7830-1XX	3.0V	±2%
CY7833-1XX	3.3V	±2%
CY7836-1XX	3.6V	±2%
CY7850-1XX	5.0V	±2%

Type selection guide

CY78①②-1③④

Designator	Symbol	Description
①②	Integer	Output Voltage(2.8V~5.0V)
③	P	Package:SOT89
	M	Package:SOT23-3
	M5	Package:SOT23-5
④	R	RoHS / Pb Free
	G	Halogen Free

Note:“①②” stands for output voltages. Other voltages can be specially customized.

Block Diagram and Pin Arrangement Diagram

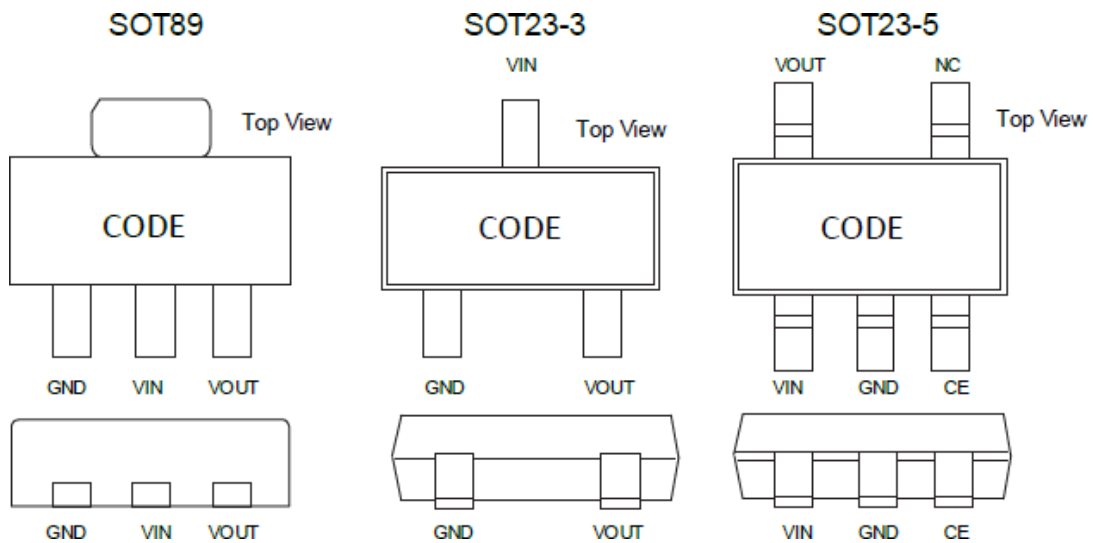
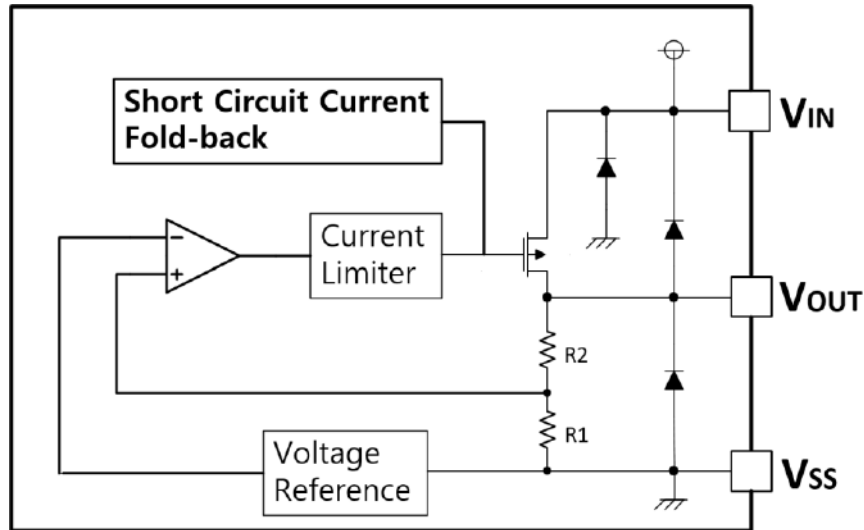

Pin Assignment

Pin Name	Description
GND	Ground connection.
VIN	Supply Voltage Input.
VOUT	Output.
CE	Enable pin, active at high level.(SOT23-5)



Functional Description

The CY78XX-1 series is a group of positive voltage output, three-pin regulators, that provide a high current even when the input/output voltage differential is small. The CY78XX-1 consists of a high-precision voltage reference, an error amplification circuit, and a current limited output driver.

Absolute Maximum Ratings

Parameter	Symbol	Value	Unit
Supply Voltage Input	VIN	-0.3~18	V
Operating Temperature	Tamb	-40~85	°C
Storage Temperature	Tstg	-40~125	°C

Note: These are stress ratings only. Stresses exceeding the range specified under “Absolute Maximum Ratings” may cause substantial damage to the device. Functional operation of this device at other conditions beyond those listed in the specification is not implied and prolonged exposure to extreme conditions may affect device reliability.

Electrical Characteristics

CY78XX-1 for any output type (Ta=25°C)

Parameter	Symbol	Test Conditions	Min.	Typ.	Max.	Unit
Output Voltage	V_{OUT}	$V_{IN}=V_{OUT}+1V$ $1.0mA \leq I_{OUT} \leq 30mA$	$V_{OUT} \times 0.98$	-	$V_{OUT} \times 1.02$	V
Output Current	I_{OUT}	$V_{IN} - V_{OUT}=1V$	-	500	-	mA
Low dropout	V_{drop}	Refer to the next table				
Line Regulation	$\frac{\Delta V_{OUTL}}{V_{IN} \times V_{OUT}}$	$1.6V \leq V_{IN} \leq 8V$ $I_{OUT}=100mA$	-	0.05	0.2	%/V
Load Regulation	ΔV_{OUT}	$V_{IN}=V_{OUT}+1V$ $1.0mA \leq I_{OUT} \leq 100mA$	-	12	30	mV
Output Voltage Temperature Coefficiency	$\frac{\Delta V_{OUT}}{Ta \times V_{OUT}}$	$I_{OUT}=30mA$ $0^{\circ}C \leq Ta \leq 70^{\circ}C$	-	± 100	-	ppm/ °C
PSRR	PSRR	F=1KHz $V_{IN}=V_{OUT}+1V$	-	40	-	dB
Supply Current	I_{ss1}	-	-	1	2	uA
Input Voltage	V_{IN}	-	3.5	-	15	V

Electrical Characteristics by Output Voltage:

Output Voltage $V_{OUT}(V)$	Dropout Voltage $V_{dif} (V)$		
	Conditions	Typ.	Max.
$V_{OUT} \leq 2.0V$	$I_{OUT}=60mA$	0.1	0.12
$2.0 < V_{OUT} \leq 3.0$	$I_{OUT}=80mA$	0.12	0.14
$3.0 < V_{OUT} \leq 4.0$	$I_{OUT}=100mA$	0.16	0.18
$4.0 < V_{OUT} \leq 5.0$		0.17	0.18
$3.0 < V_{OUT} \leq 4.0$	$I_{OUT}=200mA$	0.21	0.24
$4.0 < V_{OUT} \leq 6.0$		0.20	0.22
$3.0 < V_{OUT} \leq 4.0$	$I_{OUT}=500mA$	0.8	0.85
$4.0 < V_{OUT} \leq 6.0$		0.75	0.80

Application Circuits

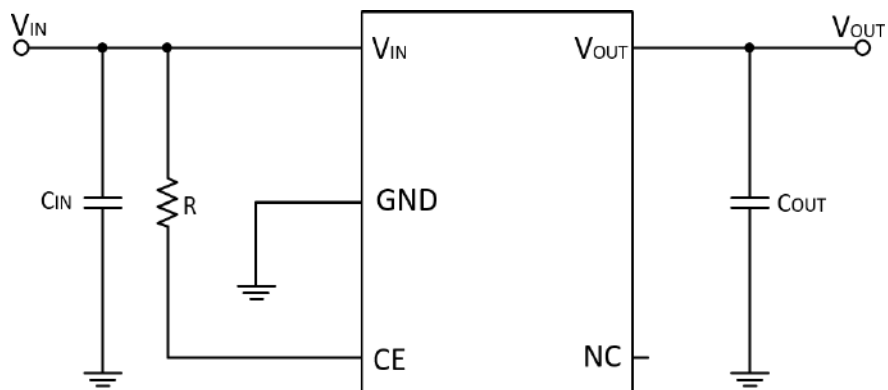
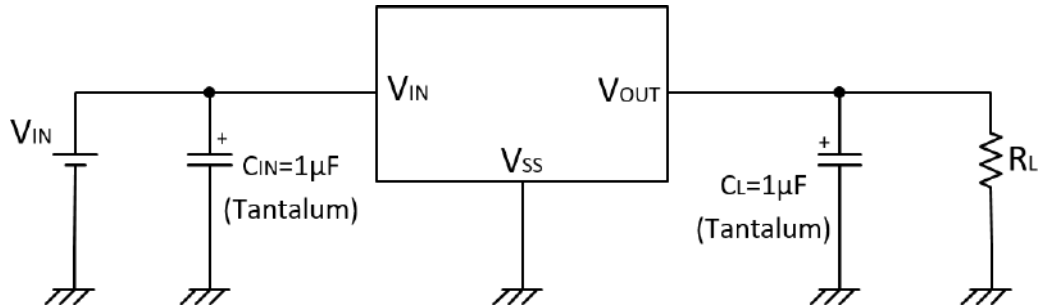

Note1: Input capacitor $C_{IN}=1\mu F$.

Note2: Output capacitor $C_{OUT}=1\mu F, R=10K$

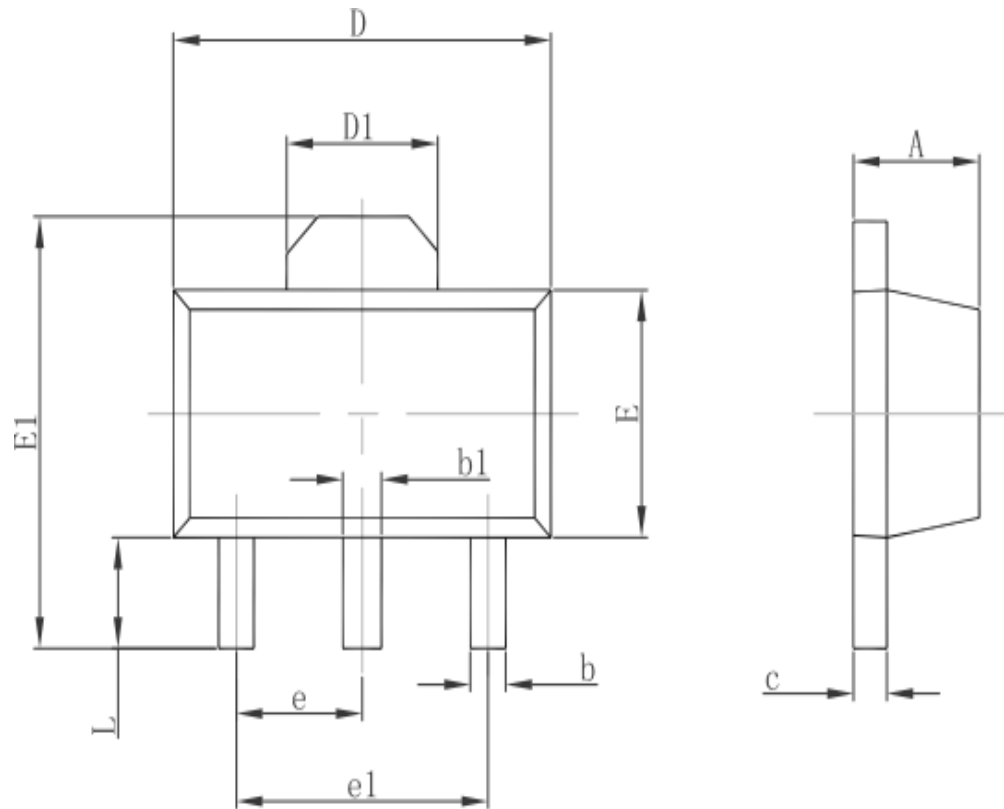
Package Information (SOT89)

Symbol	Dimensions In Millimeters		Dimensions In Inches	
	Min.	Max.	Min.	Max.
A	1.400	1.600	0.055	0.063
b	0.320	0.520	0.013	0.020
b1	0.400	0.580	0.016	0.023
c	0.350	0.440	0.014	0.017
D	4.400	4.600	0.173	0.181
D1	1.550REF.		0.061REF.	
E	2.300	2.600	0.091	0.102
E1	3.940	4.250	0.155	0.167
e	1.500TYP.		0.060TYP.	
e1	3.000TYP.		0.118TYP.	
L	0.900	1.200	0.035	0.047

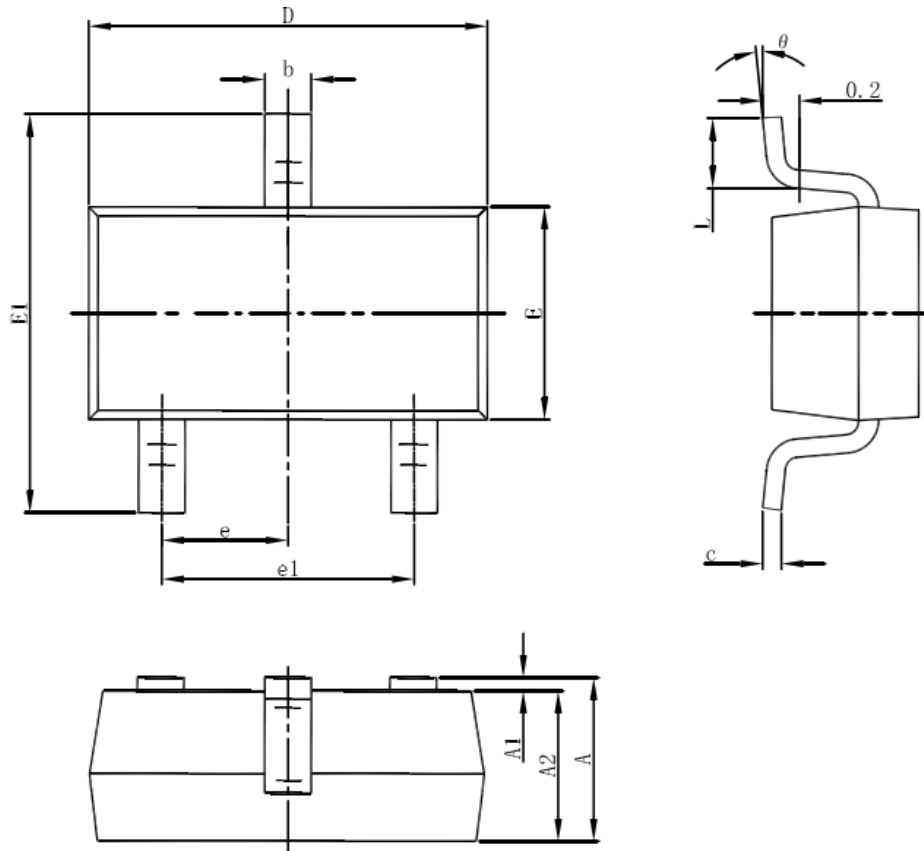
Package Information (SOT23-3)

Symbol	Dimensions In Millimeters		Dimensions In Inches	
	Min.	Max.	Min.	Max.
A	1.050	1.250	0.041	0.049
A1	0.000	0.100	0.000	0.004
A2	1.050	1.150	0.041	0.045
b	0.300	0.500	0.012	0.020
c	0.100	0.200	0.004	0.008
D	2.820	3.020	0.111	0.119
E	1.500	1.700	0.059	0.067
E1	2.650	2.950	0.104	0.116
e	0.950(BSC)		0.037(BSC)	
e1	1.800	2.000	0.071	0.079
L	0.300	0.600	0.012	0.024
θ	0°	8°	0°	8°

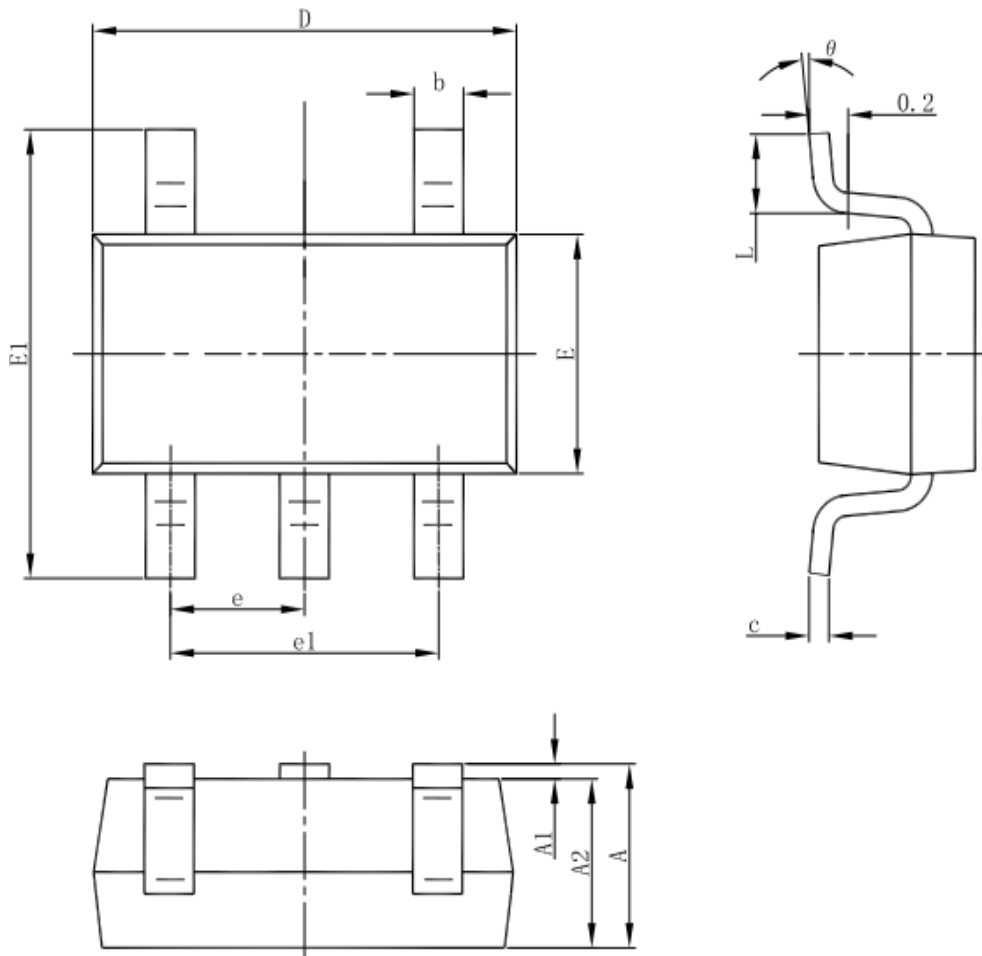
Package Information (SOT23-5)

Symbol	Dimensions In Millimeters		Dimensions In Inches	
	Min.	Max.	Min.	Max.
A	1.050	1.250	0.041	0.049
A1	0.000	0.100	0.000	0.004
A2	1.050	1.150	0.041	0.045
b	0.300	0.500	0.012	0.020
c	0.100	0.200	0.004	0.008
D	2.820	3.020	0.111	0.119
E	1.500	1.700	0.059	0.067
E1	2.650	2.950	0.104	0.116
e	0.950(BSC)		0.037(BSC)	
e1	1.800	2.000	0.071	0.079
L	0.300	0.600	0.012	0.024
θ	0°	8°	0°	8°



Special Instructions

The company reserves the right of final interpretation of this specification.

Version Change Description

Version: V1.7
2021.11.8

Author: Yangyang

Time:

Modify the record:

1. Re-typesetting the manual and checking some data
-