



SYN531R

300MHz to 450MHz ASK Receiver

FEARURES

- 300MHz to 450MHz Frequency Range
- -109dBm High Sensitivity, 1Kbps and BER 10E-2 @ 315MHz and 433.92MHz
- Image Rejection Function
- Low Power Consumption
- Excellent Selectivity and Noise Rejection
- No External IF Filter Required
- Low External part count
- SOP-8 Package Type

Applications

- Automotive Remote Keyless Entry (RKE)
- Remote Control System
- Access Control System
- Home Automation
- Toys

DESCRIPTION

The SYN531R is an UHF ASK receiver IC in a small SOP-8 package which operates at 300MHz to 450MHz with typical receiving sensitivity of -109dBm.

The SYN531R is a Weaver architecture receiver for ASK and OOK modulation such as pulse width modulation, variable pulse modulation, Manchester modulation and so on. The Weaver receiver also provides image rejection function to remove the image band and selects the desired signal.

The high integrated SYN531R uses the low cost 8-Lead Small Outline Package (SOP-8), no extra external component is required except two capacitors (CTH and CAGC), reference crystal and antenna matching network.

The SYN531R provides the Shut Down function pin (SHDN).

TYPICAL APPLICATION

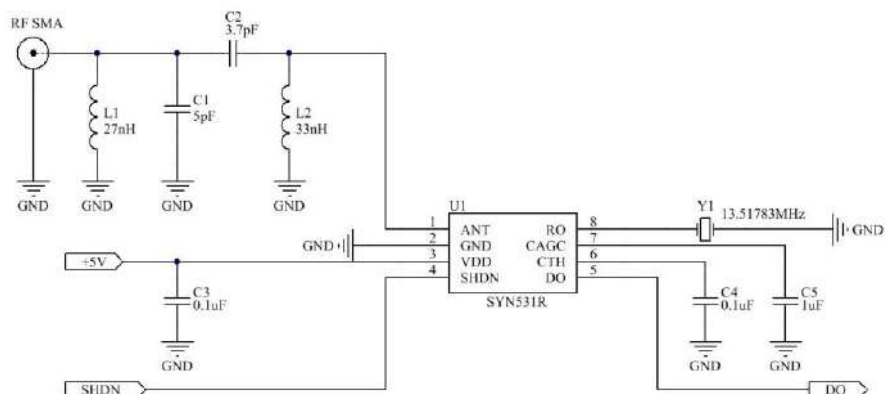

433.92MHz, 1KHz Baud Rate Application Circuit

SYN531R requires only three components to operate: two capacitors (CTH and CAGC) and the reference frequency device, usually a quartz crystal. Additional five components may be used to improve performance. These are: power supply decoupling capacitor, two components for the matching network, and two components for the pre-selector band pass filter.

PIN CONFIGURATION

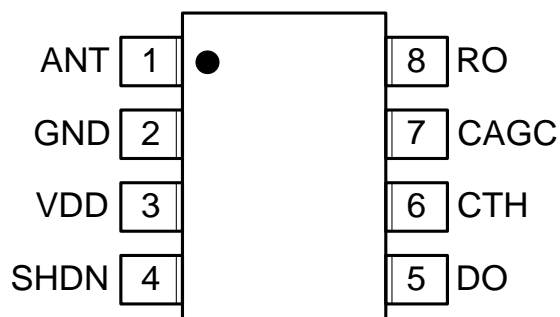

SYN531R SOP-8

PIN DESCRIPTION

Pin	Name	I/O	Function
1	ANT	I	RF Input
2	GND	GND	Ground
3	VDD	POWER	Power Supply
4	SHDN	I	Shut Down
5	DO	O	Data Output
6	CTH	I	Slicing Level Capacitor
7	CAGC	I	Filter capacitor Connected to AGC
8	RO	I	Reference Crystal Oscillator

ABSOLUTE MAXIMUM RATINGS

Supply Voltage	7V	Storage Temperature Range	-65°C to 150°C
Input Voltage	7V	Junction Temperature	150°C
ESD Rating	Note 1	Lead Temperature (soldering, 10sec.)	260°C

OPERATING RATINGS

Supply Voltage	3.6V to 5.5V	Ambient Temperature (T _A)	-40°C to 85°C
Input Voltage (Max.)	5.5V		

ELECTRICAL CHARACTERISTICS

Unless otherwise noted, VDD = 5V, CAGC = 1μF, CTH = 0.1μF, 1Kbps data rate (Manchester encoded, BER = 10E-2), all test at T_A = 25°C.

Receiver

Symbol	Parameter	Conditions	Min.	Typ.	Max.	Units
f _{RX}	Frequency Input Range		300 to 450			MHz
P _{IN,MAX}	Maximum Input Power				10	dBm
P _{SENS}	Receiver Sensitivity (Note 2)	f _{RX} = 315MHz		-109		dBm
		f _{RX} = 433.92MHz		-109		dBm
	Image Rejection	f _{RX} = 315MHz		20		dB
		f _{RX} = 433.92MHz		20		dB
f _{IF}	1 st IF Center Frequency	f _{RX} = 315MHz		0.86		MHz
		f _{RX} = 433.92MHz		1.2		MHz
	IF Bandwidth	f _{RX} = 315MHz		235		KHz
		f _{RX} = 433.92MHz		330		KHz
	Receive Modulation Duty Cycle	Note 3	20		80	%
V _{AGC}	AGC Dynamic Voltage	P _{IN} = -40dBm		1.15		V
		P _{IN} = -100dBm		1.7		V

Reference Oscillator

Symbol	Parameter	Conditions	Min.	Typ.	Max.	Units
f _{OSC}	Frequency	f _{RX} = 315MHz	9.8131			MHz
		f _{RX} = 433.92MHz	13.51783			MHz
	Input Range		0.2		1.5	V _{PP}
I _{OSC}	Source Current	V(RO) = 0V		3.5		μA

DO Drive

Symbol	Parameter	Conditions	Min.	Typ.	Max.	Units
	DO pin Output Current	Source @ 0.8VDD		260		μA
		Sink @ 0.2 VDD		600		μA
T _{RISE}	Output Rise and Fall Times	C _L = 15pF, pin DO, 10-90%		2		μsec
T _{FALL}				2		μsec

Power Supply

Symbol	Parameter	Conditions	Min.	Typ.	Max.	Units
I _{CC}	Supply Current @ VDD = 5V	f _{RX} = 315MHz		4.5		mA
		f _{RX} = 433.92MHz		7.0		mA
I _{OFF}	Shut Down Current	SHDN = High		0.5		μA

Note 1: Device is ESD sensitive. Use appropriate ESD precautions. Exceeding the absolute maximum rating may damage the device.

Note 2: Sensitivity is defined as the average signal level measured at the input necessary to achieve 10⁻² BER (bit error rate). The input signal is defined as a return-to-zero (RZ) waveform with 50% average duty cycle (Manchester encoded) at a data rate of 1kbps.

Note 3: When data burst does not contain preamble, duty cycle is defined as total duty cycle, including any “quiet” time between data bursts. When data bursts contain preamble sufficient to charge the slice level on capacitor CTH, then duty cycle is the effective duty cycle of the burst alone.

[For example, 100msec burst with 50% duty cycle, and 100msec “quiet” time between bursts. If burst includes preamble, duty cycle is $T_{ON}/(T_{ON} + T_{OFF}) = 50\%$; without preamble, duty cycle is $T_{ON}/(T_{ON} + T_{OFF} + T_{QUIET}) = 50\text{msec}/(200\text{msec}) = 25\%$. T_{ON} is the (Average number of 1's/burst) × bit time, and $T_{OFF} = T_{BURST} - T_{ON}$.]

TYPICAL CHARACTERISTICS

Unless otherwise noted, VDD = 5V, CAGC = 1 μ F, CTH = 0.1 μ F, 1Kbps data rate (Manchester encoded, BER = 10E-2), all test at T_A = 25°C.

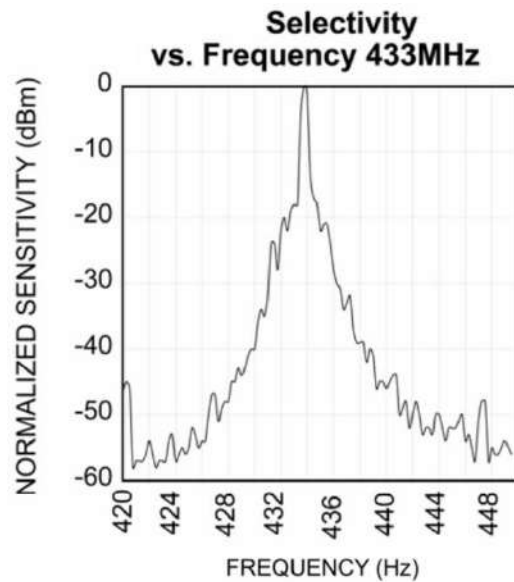
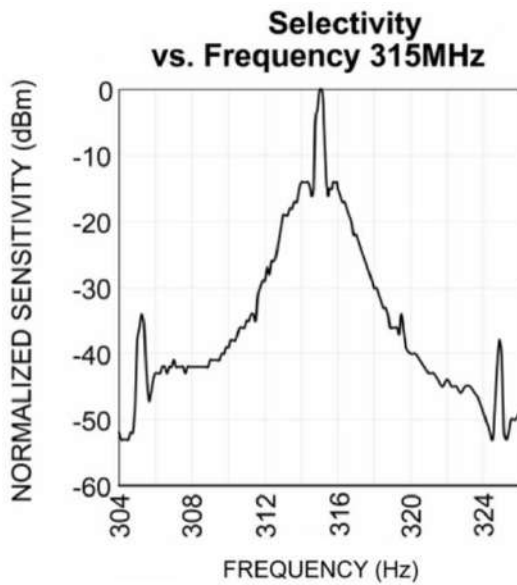
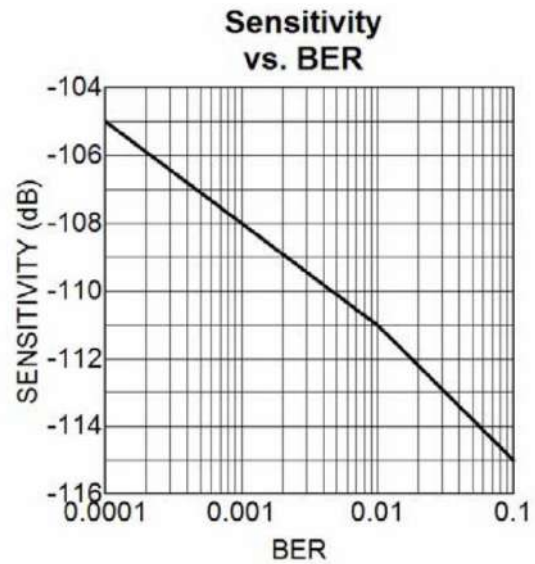
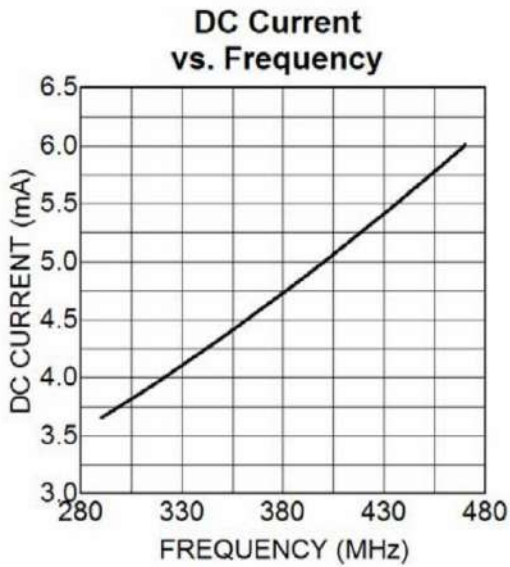

BLOCK DIAGRAM

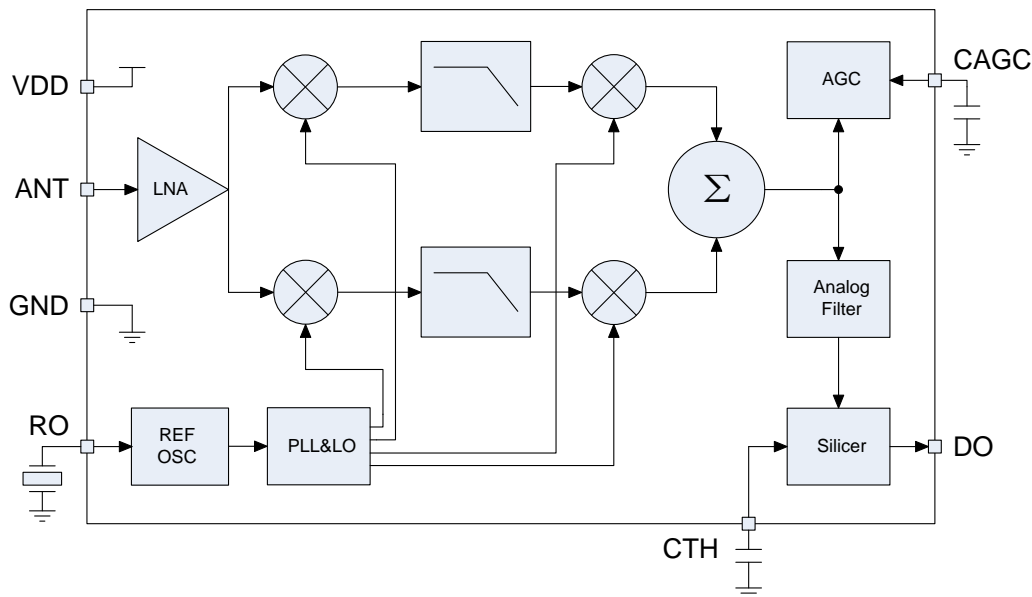

Figure 1 Simplified Block Diagram

FUNCTIONAL DESCRIPTION

Figure 1 Simplified Block Diagram that illustrates the basic structure of the SYN531R. It is composed of five modules; Low Noise Amplifier, Weaver architecture receiver, the Slicer, Auto Gain Control and Reference and Control Logics.

LNA

The RF input signal is AC-coupled into the gate circuit of the grounded source LNA input stage. The LNA uses a Cascoded NMOS structure circuit, and the output is converted to differential signals for next stage mixers.

Weaver Receiver

The LNA output signals are first mixed with quadrature phases of the local oscillator signal. After filtering both mixer output with a low-pass filter, the output signals are mixed again by another set of mixing operation in both signal paths, the sum of the two final signals cancels the image band to yield the desired signal, while the subtraction removes the desired signal and selects the image band.

Slicer

The signal prior to slicer is still linear demodulated AM. Data slicer converts this signal into digital "1" and "0" by comparing with the threshold voltage built up on the CTH capacitor. This

threshold is determined by detecting the positive and negative peaks of the data signal and storing the mean value. Slicing threshold is at 50%. After the slicer, the signal is now digital OOK data. During long periods of "0" or no data period, threshold voltage on the CTH capacitor may be very low. Large random noise spikes during this time may cause erroneous "1" at DO pin.

AGC

The AGC comparator monitors the signal amplitude from the output of the Weaver receiver. When the output signal is less than 750mV, the threshold 1.5 μ A current is sourced into the external CAGC capacitor. When the output signal is greater than 750mV, a 15 μ A current sink discharges the CAGC capacitor. The voltage developed on the CAGC capacitor acts to adjust the gain of the mixers of Weaver receiver to compensate for RF input signal level variation.

Reference Oscillator

The reference oscillator in the SYN531R uses a basic Colpitts crystal oscillator configuration with MOS transistor to provide negative resistance. The RO pin external capacitor is integrated inside SYN531R. User only needs to connect reference oscillation crystal. Reference oscillator crystal frequency can be calculated: $F_{OSC} = F_{RF}/(32 + 1.198/12)$
For 433.92 MHz, $F_{OSC} = 13.51783$ MHz.

EVALUATION BOARD

Figure 2, 3 and 4 show the top, bottom and top solder layers of the SYN531R @433.92MHz application board. Keep traces as short as possible. Long traces will alter the matching network, and the values suggested will not be valid. Ground plane must be solid and possibly without interruptions. Avoid ground plane on top next to the matching elements. It normally adds additional stray capacitance which changes the matching. RF path should be as straight as possible avoiding loops and unnecessary turns.

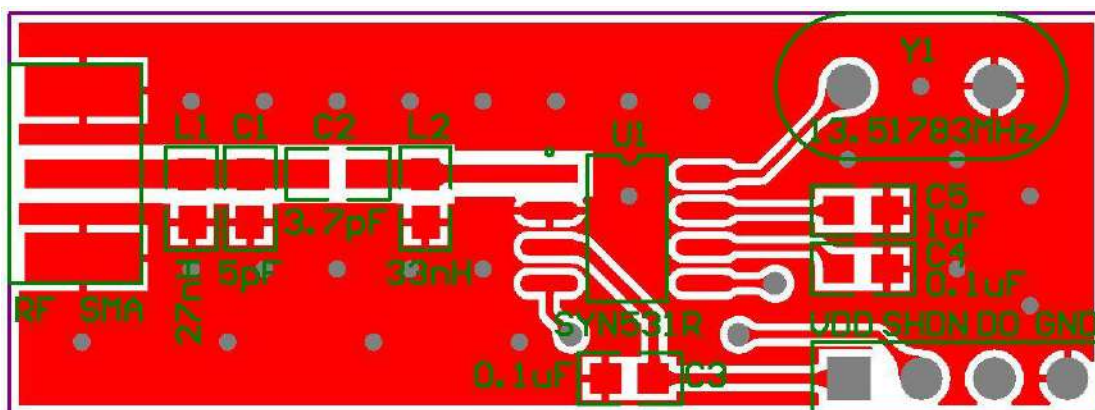

Figure 2 Top Layer

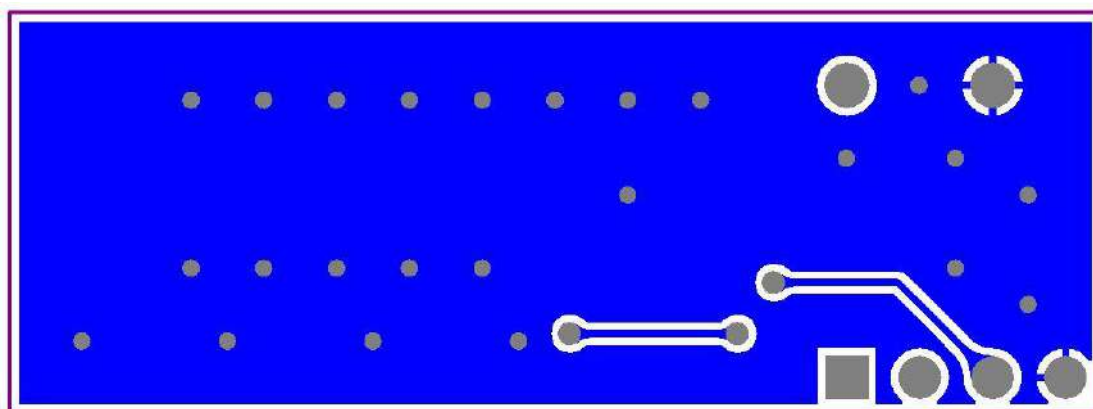

Figure 3 Bottom Layer

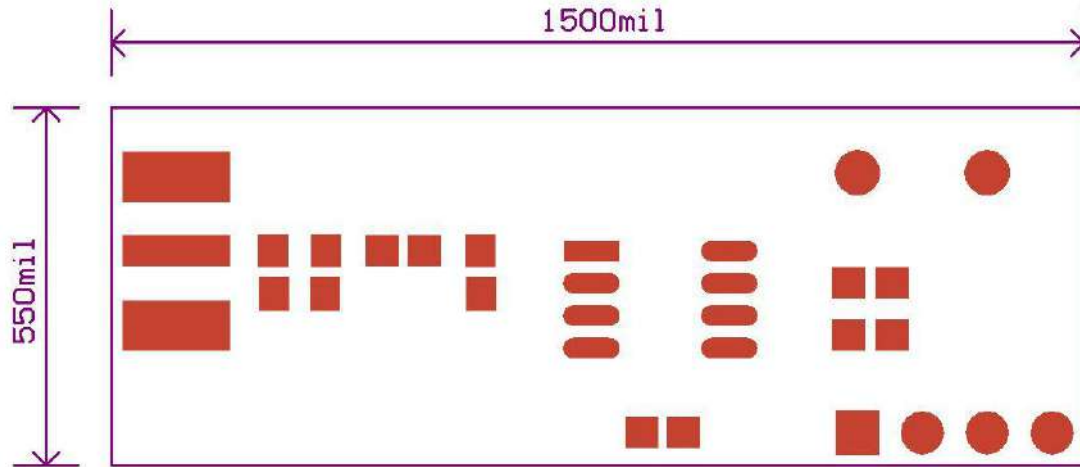
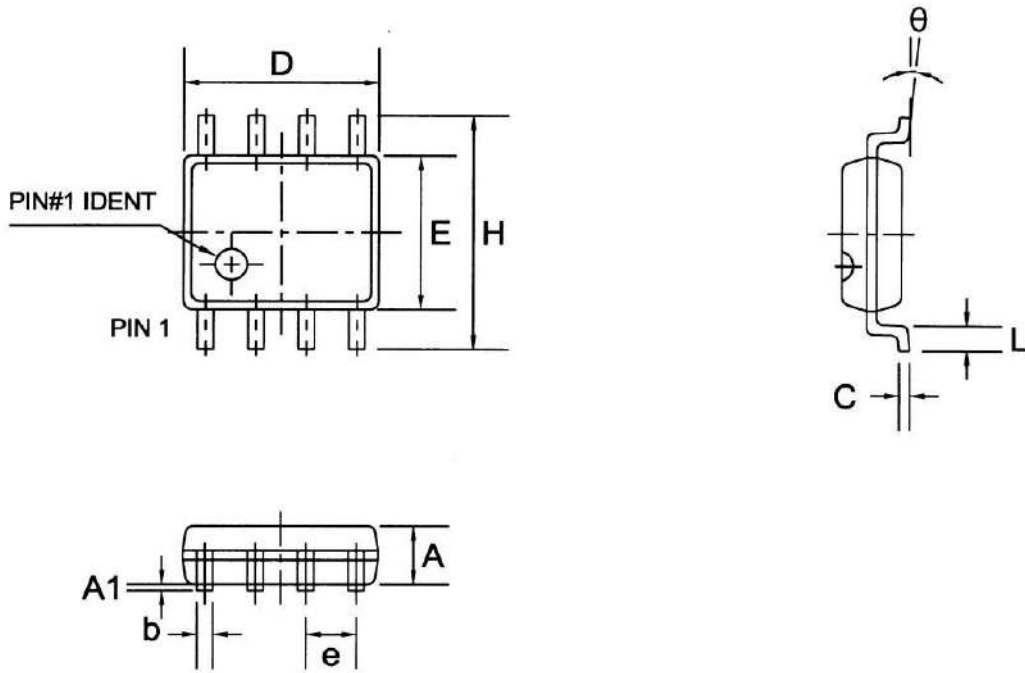

Figure 4 Top Solder Layer with Dimensions

BOARD BILL OF MATERIALS

Footprint	Comment	Designator	Description	Quantity
0603-STD	5pF	C1	Capacitor	1
0603-STD	3.7pF	C2	Capacitor	1
0603-STD	0.1μF	C3, C4	Capacitor	2
0603-STD	1μF	C5	Capacitor	1
0603-STD	27nH	L1	Inductor	1
0603-STD	33nH	L2	Inductor	1
SMA-KHD	RF SMA	P1	SMA Connector	1
HDR1X4	Header 4	P2	Header, 4-Pin	1
SOP-8	SYN531R	U1	SYNOXO	1
XTAL-HC49S	13.51783MHz	Y1	Crystal Oscillator	1

PACKAGE DESCRIPTION



Symbol	Dimensions In Millimeters			Dimensions In Inches		
	Min	Nom	Max	Min	Nom	Max
A	1.30	1.50	1.70	0.051	0.059	0.067
A1	0.06	0.16	0.26	0.002	0.006	0.010
b	0.30	0.40	0.55	0.012	0.016	0.022
C	0.15	0.25	0.35	0.006	0.010	0.014
D	4.72	4.92	5.12	0.186	0.194	0.202
E	3.75	3.95	4.15	0.148	0.156	0.163
e	—	1.27	—	—	0.050	—
H	5.70	6.00	6.30	0.224	0.236	0.248
L	0.45	0.65	0.85	0.018	0.026	0.033
theta	0°	—	8°	0°	—	8°

SOP-8 Package Outline Dimensions shown in millimeters and (inches)