Current 300mA High Voltage 40V Low Power LDO

CYP7901

General Description

The CYP7901 series is a group of positive voltage output, three-pin regulators, that provide a high current even when the input/output voltage differential is small. Low power consumption and high accuracy is achieved through CMOS and laser trimming technologies.

The CYP7901 consists of a high-precision voltage reference, an error amplification circuit, and a current limited output driver. Transient response to load variations have improved in comparison to the existing series.



SOT23-3L



SOT23-5L



SOT89-3L



SOT223

Features

- Low Quiescent Current: 1.6 μ A(type);
- Temperature Stability: \pm 50ppm/ $^{\circ}$ C;
- Max input voltage: 40V;
- Output voltage accuracy: tolerance \pm 2%;
- Dropout Voltage: 20mV@Iout=10mA, 350mV@Iout=100mA;
- Max Output Current: 300mA;
- Protections Circuits: Current Limiter, Short Circuit, thermal shutdown
- Packages: SOT23-3L、SOT23-5L、SOT89-3L、SOT223;

Applications

- Industrial control
- Consumer electronics
- Battery power equipment
- Wireless communication equipment

**Order information**

Product model	Package	Manner of packing	Minimum packing quantity
CYP7901PxxMx	SOT23-3L	Reel	3000
CYP7901PxxM5x	SOT23-5L		3000
CYP7901PxxPx	SOT89-3L		1000
CYP7901PxxPBx	SOT89-3L(B)		1000
CYP7901PxxFx	SOT223		2500
CYP7901PxxFBx	SOT223(B)		2500

Selection Guide Table**CYP7901P①②③④**

Designator	Symbol	Description
①②	Integer	Output Voltage(3.0V~12.0V)
③	M	Package:SOT23-3L
	M5	Package:SOT23-5L
	P	Package:SOT89-3L
	PB	Package:SOT89-3L(B)
	F	Package:SOT223
	FB	Package:SOT-223(B)
④	R	RoHS / Pb Free
	G	Halogen Free

Note: ①②stands for output voltages. Other voltages can be specially customized.

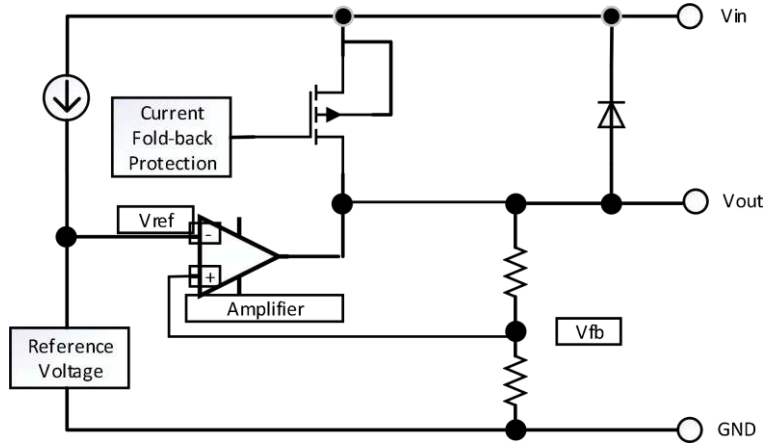
Functional Block Diagram

Pin Configuration (Top View)

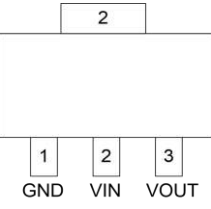
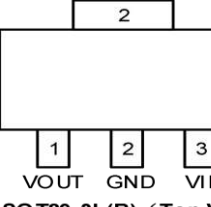
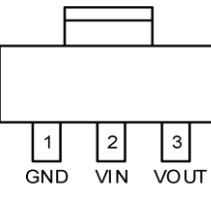
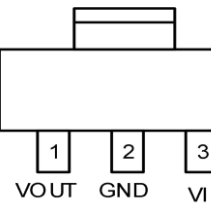
CYP7901PxxMx		
NO.	Description	
1	GND	<p style="text-align: center;">SOT23-3L (Top View)</p>
2	V_{out}	
3	V_{in}	
MARK	01Mxx YWH	
CYP7901PxxM5x		
NO.	Description	
1	V_{in}	<p style="text-align: center;">SOT23-5L (Top View)</p>
2	GND	
3	NC	
4	NC	
5	V_{out}	
MARK	01M5xx YWH	

CYP7901PxxPx		
NO.	Description	
1	GND	 <p style="text-align: center;">GND VIN VOUT</p> <p style="text-align: center;">SOT89-3L (Top View)</p>
2	Vin	
3	Vout	
MARK	01Pxx YWH	
CYP7901PxxPBx		
NO.	Description	
1	Vout	 <p style="text-align: center;">VOUT GND VIN</p> <p style="text-align: center;">SOT89-3L(B) (Top View)</p>
2	GND	
3	Vin	
MARK	01PBxx YWH	
CYP7901PxxFx		
NO.	Description	
1	GND	 <p style="text-align: center;">GND VIN VOUT</p> <p style="text-align: center;">SOT-223 (Top View)</p>
2	Vin	
3	Vout	
MARK	01Pxx YWH	
CYP7901PxxFBx		
NO.	Description	
1	Vout	 <p style="text-align: center;">VOUT GND VIN</p> <p style="text-align: center;">SOT-223 (B) (Top View)</p>
2	GND	
3	Vin	
MARK	01FBxx YWH	

Note: xx: Output Voltage, "33" stands for 3.3V

Y: The Year of manufacturing, "2" stands for year 2022;

W: The week of manufacturing. "20" stands for week 20;

H: Factory Code;

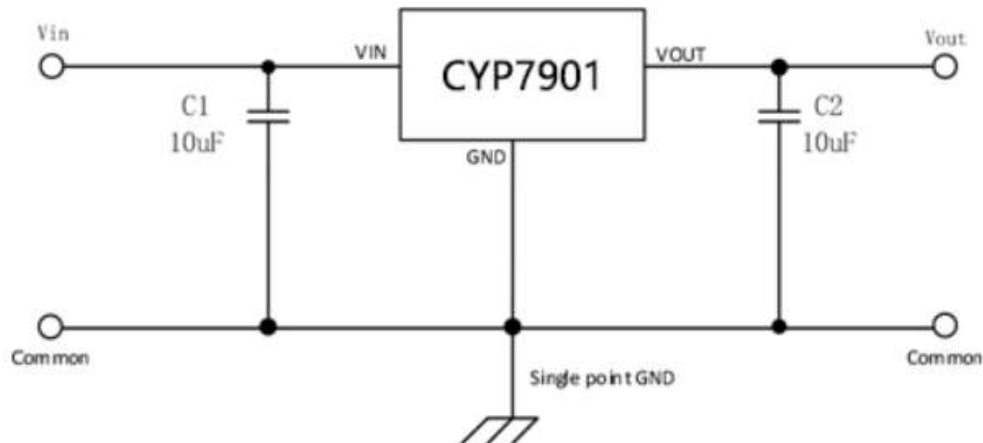
Application Circuits

Absolute Maximum Ratings

 (Unless otherwise indicated: $T_a=25^{\circ}\text{C}$)

PARAMETER	SYMBOL	MIN	MAX	UNITS
Input Voltage	V_{IN}	-0.3	40	V
Output Voltage	V_{OUT}	$V_{SS}-0.3$	$V_{IN}+0.3V$	
Output Current	I_{out}	-	300	mA
Power Dissipation	⁽¹⁾ P_D		SOT23-3 220 SOT23-5 220 SOT-89 650 SOT 223 1000	mW
Operating Ambient Temperature	T_{opr}	-40	85	$^{\circ}\text{C}$
Storage Temperature	T_{stg}	-40	125	
ESD Protection	ESD HBM		2000	V

Note: These are just the limit parameters. Beyond the range specified in the Absolute Maximum Ratings may cause serious damage to the equipment. Long exposure to extreme conditions may affect the reliability of the device.

(1)Increasing the welding area of package is beneficial to increase power consumption

Recommended Operating Conditions

PARAMETER	SYMBOL	MIN	MAX	UNITS
Input Voltage	V_{IN}	-0.3	36	V
Operating Ambient Temperature	T_{opr}	-40	85	$^{\circ}\text{C}$

Note: Always use semiconductor devices within their recommended operating condition ranges.

Operation outside these ranges may adversely affect reliability



Electrical Characteristics

CYP7901 Series (Unless otherwise indicated: $T_a=25^{\circ}\text{C}$)

PARAMETER	SYMBOL	CONDITIONS	MIN	TYP	MAX	UNIT	
Output Voltage ¹	$V_{OUT(S)}$	$V_{IN}=V_{OUT(S)}+2V, I_{OUT}=10\text{mA}$	$V_{OUT(S)}\times 0.98$	$V_{OUT(S)}$	$V_{OUT(S)}\times 1.02$	V	
Dropout Voltage ²	V_{DROP}	$I_{OUT}=10\text{mA}$	-	20	-	mV	
		$I_{OUT}=100\text{mA}$		350	-		
		$I_{OUT}=200\text{mA}$		770	-		
		$I_{OUT}=300\text{mA}$	-	1380	-		
Line Regulation	$\frac{V_{OUT}}{V_{IN}} \frac{V_{OUT}}{V_{OUT}}$	$V_{OUT(S)}+2V \leq V_{IN} \leq 36V$ $I_{OUT}=10\text{mA}$	-	0.01	0.02	%/V	
Load Regulation	ΔV_{OUT2}	$V_{IN}=V_{OUT(S)}+2V$ $1\text{mA} \leq I_{OUT} \leq 300\text{mA}$	$V_{OUT(S)} \leq 10V$	40	90	mV	
			$V_{OUT(S)} > 10V$	85	150		
Temperature Stability	$\frac{V_{OUT}}{T_a}$	$V_{IN}=V_{OUT(S)}+2V, I_{OUT}=10\text{mA}$ $-40^{\circ}\text{C} \leq T_a \leq 85^{\circ}\text{C}$		± 50		ppm/ $^{\circ}\text{C}$	
Quiescent Current	I_q	no load	$V_{OUT(S)} < 3.0V$	0.8	1.2	2	μA
			$3.0 \leq V_{OUT(S)} \leq 40V$	1	1.6	3	
Input Voltage	V_{IN}	---	2.2		40	V	
Maximum Output Current	I_{OUTMAX}			300		mA	
Current Limit ³	I_{LIM}	$V_{IN}=V_{OUT(S)}+1V,$ $V_{OUT}=0.98 \times V_{OUT(S)}$		340		mA	
Short Circuit Current	I_{SHORT}	$V_{IN}=V_{OUT(S)}+2V, V_{OUT}$ Short to GND with 0Ω		140		mA	
Power Supply Rejection Ratio	PSRR	$f=10\text{Hz}, V_{OUT(S)}=3.3V$		70		dB	
		$f=100\text{Hz}, V_{OUT(S)}=3.3V$		70			
		$f=1\text{kHz}, V_{OUT(S)}=3.3V$		55			
Over Temperature Protection	OTP	$I_{OUT}=10\text{mA}$		140		$^{\circ}\text{C}$	

Notes:

- $V_{OUT(S)}$: Output voltage when $V_{IN}=V_{out}+2V, I_{out}=1\text{mA}$.
- $V_{DROP}=V_{in1} - (V_{out(S)} \times 0.98)$ where V_{in1} is the input voltage when $V_{out} = V_{out(S)} \times 0.98$.
- I_{LIM} : Output current when $V_{in}=V_{out(S)}+1V$ and $V_{out} = 0.98 \times V_{out(S)}$.



Typical Performance Characteristics

Test Conditions: CYP7901P33P SOT-89 CIN=10μF, COUT=10μF, Ta=25°C, unless otherwise indicated.

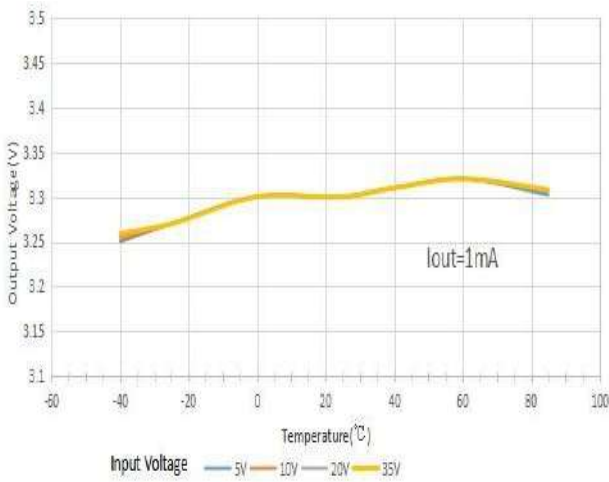

V_{OUT} vs Temperature CYP7901P33PR

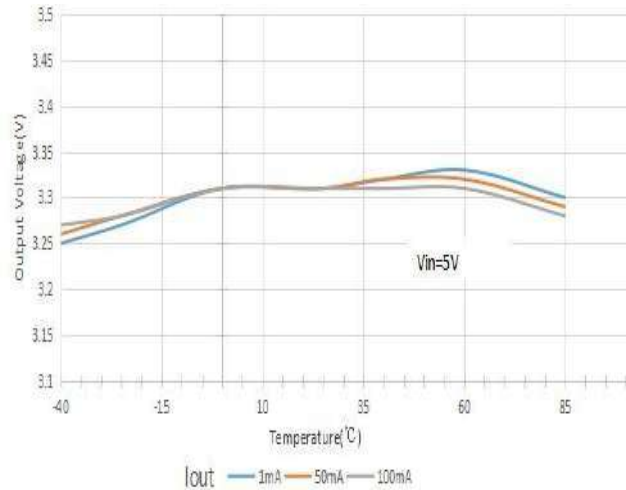

V_{OUT} vs Temperature CYP7901P33PR

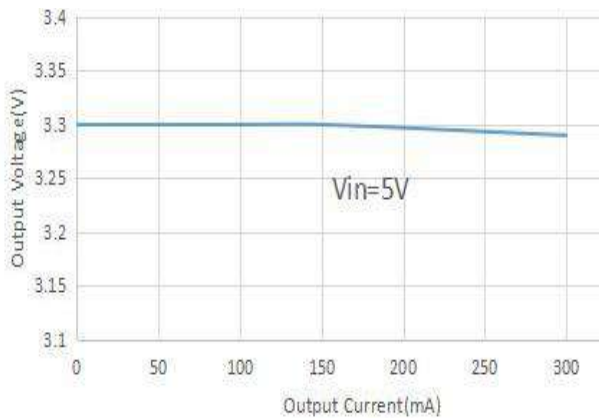

V_{OUT} Vs Output Current CYP7901P33PR

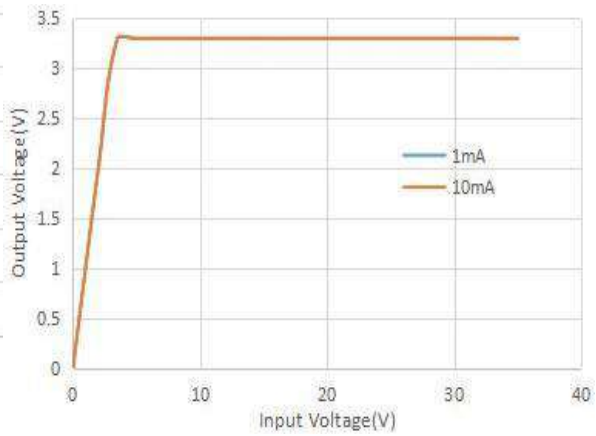

V_{OUT} Vs Input Voltage CYP7901P33PR



Typical Performance Characteristics

Test Conditions: $V_{IN}=V_{OUT}+2.0V$, $C_{IN}=10\mu F$, $C_{OUT}=10\mu F$, unless otherwise indicated.

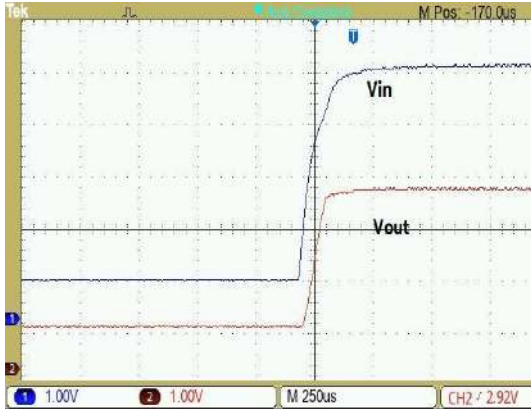

Power-Up at $V_{OUT}=3.3V$ CYP7901P33PR ($I_{OUT}=0mA$)

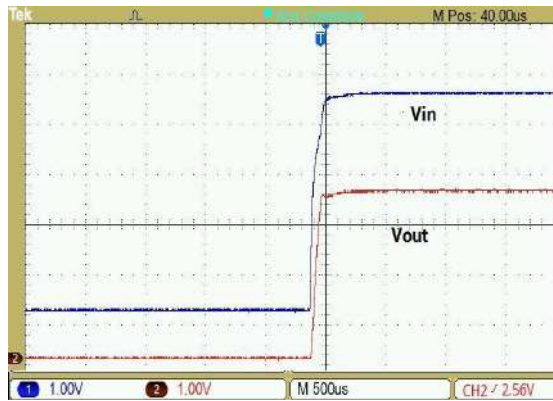

Power-Up at $V_{OUT}=3.3V$ CYP7901P33PR ($I_{OUT}=100mA$)

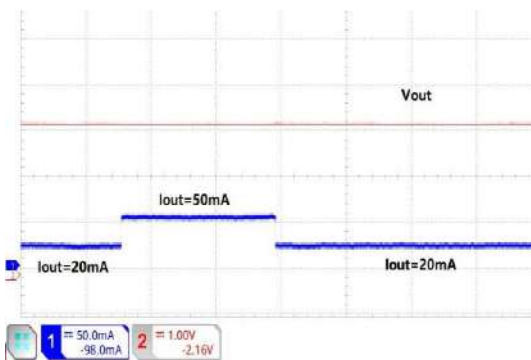

Load transient response
 $V_{out}=3.3V$, CYP7901P33PR

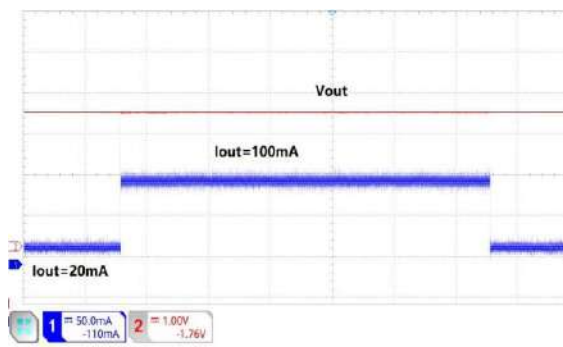

Load transient response
 $V_{out}=3.3V$, CYP7901P33PR

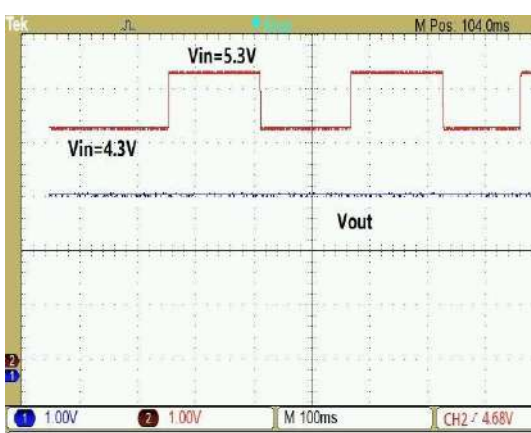

Input Voltage transient response
 $V_{out}=3.3V$, $I_{out}=10mA$, CYP7901P33PR

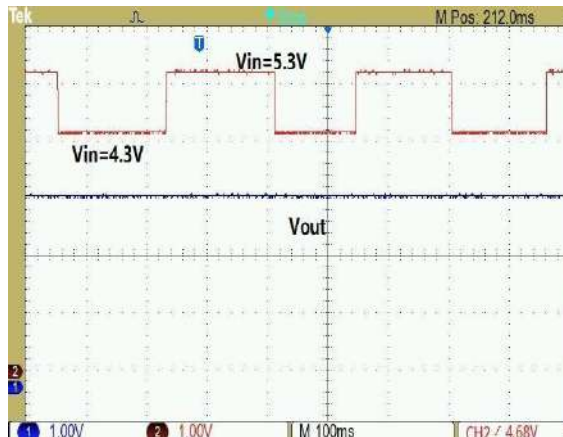

Input Voltage transient response
 $V_{out}=3.3V$, $I_{out}=100mA$, CYP7901P33PR

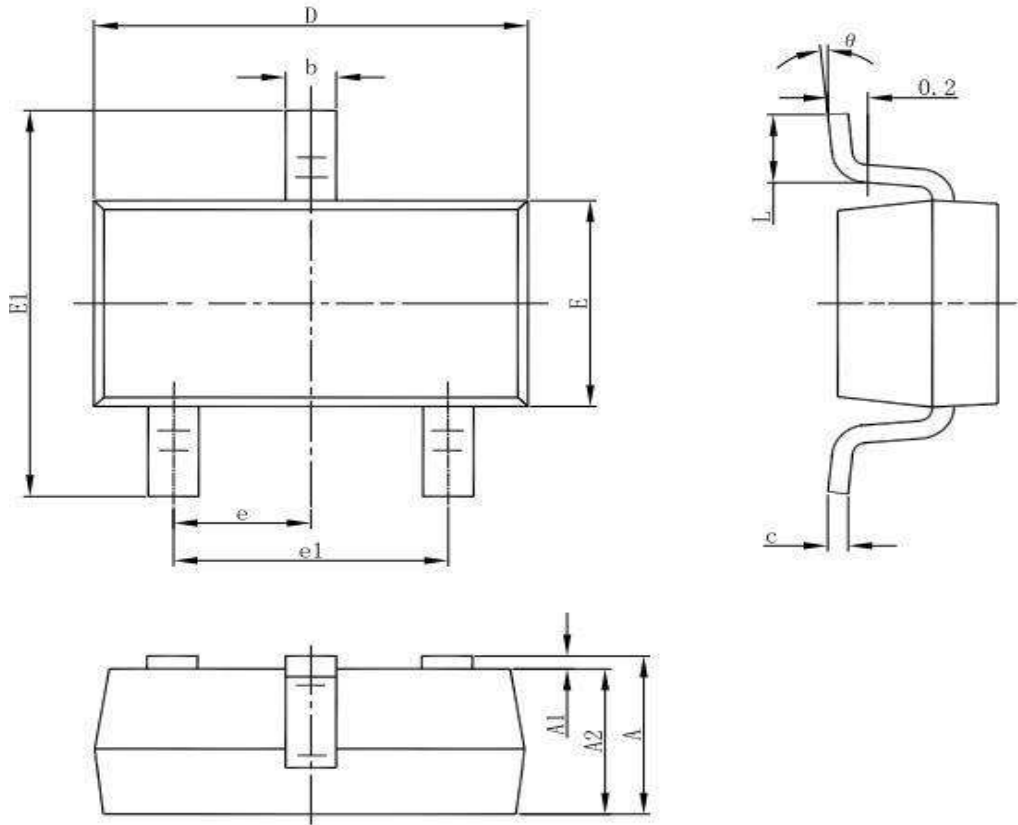
Package Information
SOT23-3 Outline Dimensions

Symbol	Dimensions In Millimeters		Dimensions In Inches	
	Min	Max	Min	Max
A	1.050	1.250	0.041	0.049
A1	0.000	0.100	0.000	0.004
A2	1.050	1.150	0.041	0.045
b	0.300	0.500	0.012	0.020
c	0.100	0.200	0.004	0.008
D	2.820	3.020	0.111	0.119
E	1.500	1.700	0.059	0.067
E1	2.650	2.950	0.104	0.116
e	0.950(BSC)		0.037(BSC)	
Ee1	1.800	2.000	0.071	0.079
L	0.300	0.600	0.012	0.024
θ	0°	8°	0°	8°

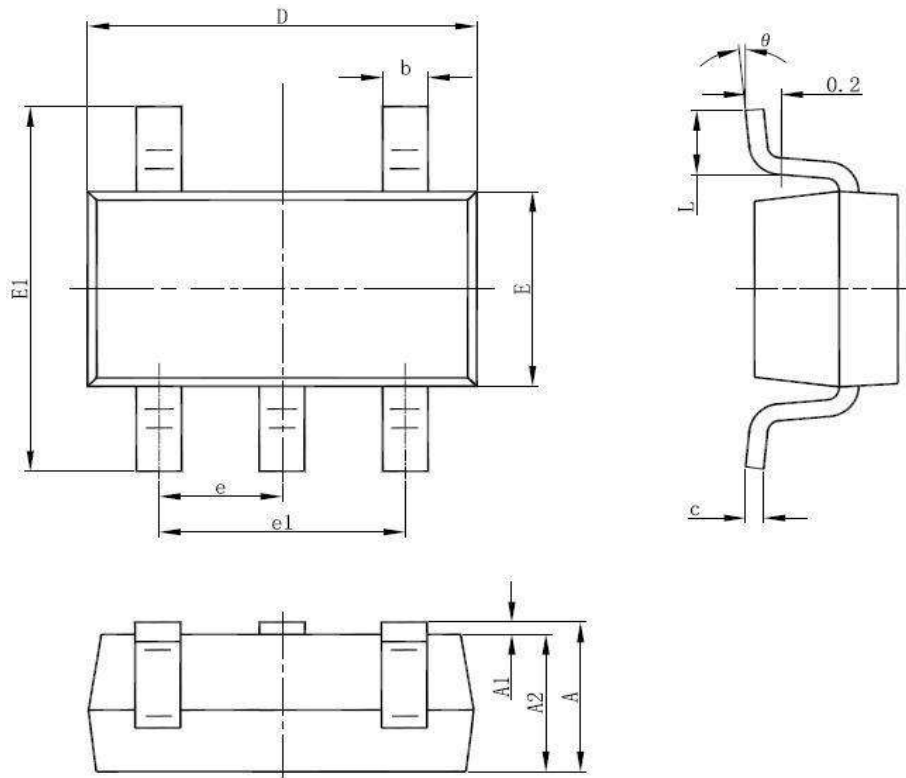
SOT23-5 Outline Dimensions

Symbol	Dimensions In Millimeters		Dimensions In Inches	
	Min	Max	Min	Max
A	1.050	1.250	0.041	0.049
A1	0.000	0.100	0.000	0.004
A2	1.050	1.150	0.041	0.045
b	0.300	0.500	0.012	0.020
c	0.100	0.200	0.004	0.008
D	2.820	3.020	0.111	0.119
E	1.500	1.700	0.059	0.067
E1	2.650	2.950	0.104	0.116
e	0.950(BSC)		0.037(BSC)	
e1	1.800	2.000	0.071	0.079
L	0.300	0.600	0.012	0.024
θ	0°	8°	0°	8°



SOT89-3L Package Outline Dimensions

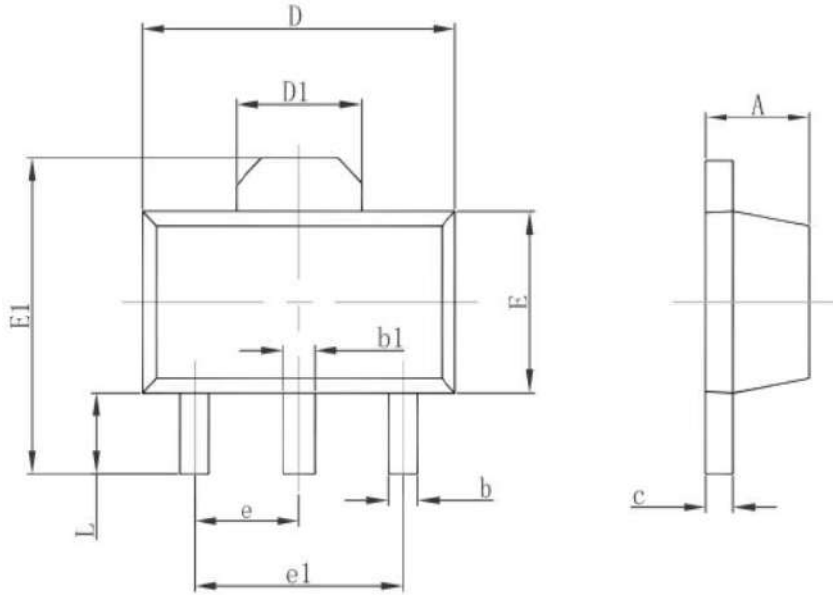

Symbol	Dimensions In Millimeters		Dimensions In Inches	
	Min	Max	Min	Max
A	1.400	1.600	0.055	0.063
b	0.320	0.520	0.013	0.020
b1	0.400	0.580	0.016	0.023
c	0.350	0.440	0.014	0.017
D	4.400	4.600	0.173	0.181
D1	1.550 REF		0.061 REF	
E	2.300	2.600	0.091	0.102
E1	3.940	4.250	0.155	0.167
e	1.500 TYP		0.060 TYP	
e1	3.000 TYP		0.118 TYP	
L	0.900	1.200	0.035	0.047

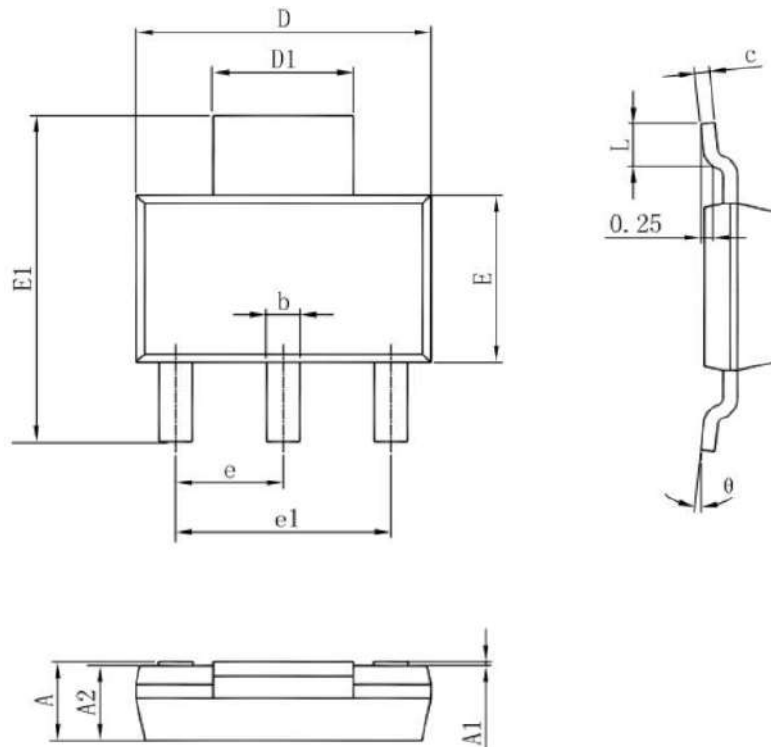
SOT223 Package Outline Dimensions

Symbol	Dimensions In Millimeters		Dimensions In Inches	
	Min	Max	Min	Max
A	1.520	1.800	0.060	0.071
A1	0.000	0.100	0.000	0.004
A2	1.500	1.700	0.059	0.067
b	0.660	0.820	0.026	0.032
c	0.250	0.350	0.010	0.014
D	6.200	6.400	0.244	0.252
D1	2.900	3.100	0.114	0.122
E	3.300	3.700	0.130	0.146
E1	6.830	7.070	0.269	0.278
e	2.300(BSC)		0.091(BSC)	
e1	4.500	4.700	0.177	0.185
L	0.900	1.150	0.035	0.045
θ	0°	10°	0°	10°



Special Version

The company reserves the right of final interpretation of this specification.

Version Change Description

Versions: V1.0

Writer: XinCHun Li

Time: 2022.05.20

Statement

The information in the usage specification is correct at the time of publication, CY Wireless Technology Limited has the right to change and interpret the specification, and reserves the right to modify the product without prior notice. Users can obtain the latest version information from our official website or other effective channels before confirmation, and verify whether the relevant information is complete and up to date.

With any semiconductor product, there is a certain possibility of failure or failure under certain conditions. The buyer is responsible for complying with safety standards and taking safety measures when using the product for system design and complete machine manufacturing. The product is not authorized to be used as a critical component in life-saving or life-sustaining products or systems, in order to avoid potential failure risks that may cause personal injury or property loss.