

200mA Current, 35V Input Voltage LDO

CY75XX-2

General Description

The CY75XX-2 series is a set of three-terminal low power high voltage regulators implemented in CMOS technology. They allow input voltages as high as 35V. They are available with several fixed output voltages ranging from 3.0V to 5.0V. CMOS technology ensures low voltage drop and low quiescent current. Although designed primarily as fixed voltage regulators, these devices can be used with external components to obtain variable voltages and currents.

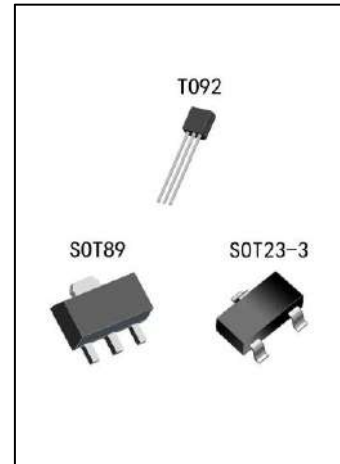

Features

- Low power consumption
- Low temperature coefficient
- Low voltage drop
- High input voltage (up to 35V)
- Output voltage accuracy: tolerance $\pm 2\%$
- TO92, SOT89 and SOT23-3 package

Applications

- Battery-powered equipment
- Communication equipment
- Audio/Video equipment



Order specification

Part No	Package	Manner of Packing	Devices per bag/reel
CY75XX-2TX	TO92	Bag	1000PCS/bag
CY75XX-2PX	SOT89	Reel	1000PCS/reel
CY75XX-2MX	SOT23-3	Reel	3000PCS/reel

Description of selection

Part No	Output Voltage	Output Voltage Accuracy
CY7530-2XX	3.0V	±2%
CY7533-2XX	3.3V	±2%
CY7536-2XX	3.6V	±2%
CY7544-2XX	4.4V	±2%
CY7550-2XX	5.0V	±2%

Print rules

Package	Marking
TO92	75XX-H#
SOT89	75XX-H#
SOT23-3	XX-H

Note: "XX" stands for output voltages. Other voltages can be specially customized. TO92 & SOT89 packages will add a "#" mark at the end of the marking.

Type selection guide

CY75 ① ② ③ ④ ⑤

Designator	Symbol	Description
① ②	Integer	Output Voltage(3.0~5.0V)
③	-2	Standard
④	T	Package:TO-92
	P	Package:SOT89
	M	Package:SOT23-3
⑤	R	RoHS / Pb Free
	G	Halogen Free

Block Diagram and Pin Arrangement Diagram

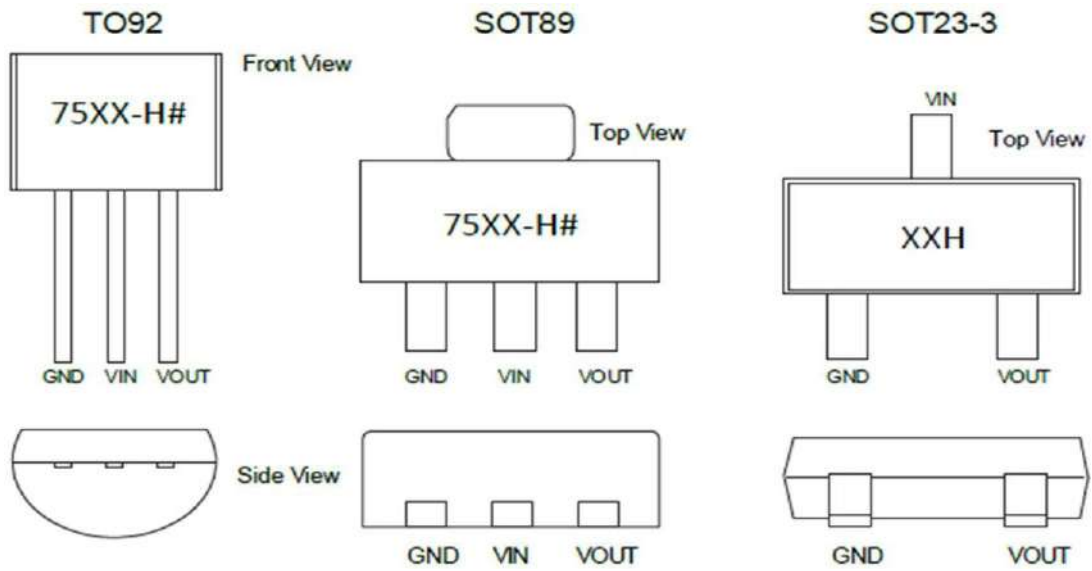
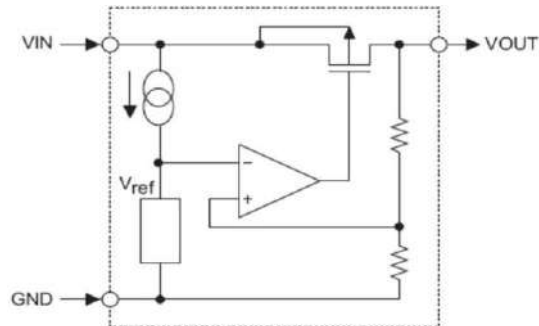

Pin Assignment

Pin No.	Pin Name	Description
1	GND	Ground connection.
2	VIN	Supply Voltage Input.
3	VOUT	Output.



Functional Description

The CY75XX-2 series is a set of three-terminal low power high voltage regulators implemented in CMOS technology. They allow input voltages as high as 35V. They are available with several fixed output voltages ranging from 3.0V to 5.0V.

Absolute Maximum Ratings

Parameter	Symbol	Value	Unit
Supply Voltage Input	V _{IN}	-0.3~35	V
Operating Temperature	T _{amb}	-40~85	°C
Storage Temperature	T _{stg}	-50~125	°C

Note: These are stress ratings only. Stresses exceeding the range specified under “Absolute Maximum Ratings” may cause substantial damage to the device. Functional operation of this device at other conditions beyond those listed in the specification is not implied and prolonged exposure to extreme conditions may affect device reliability.

Thermal Information

Parameter	Symbol	Package	Max.	Unit
Thermal Resistance (Junction to Ambient) (Assume no ambient airflow, no heat sink)	θ_{JA}	SOT23-3	500	°C/W
		SOT89	200	°C/W
		TO92	200	°C/W
Power Dissipation	P _D	SOT23-3	0.20	W
		SOT89	0.50	W
		TO92	0.50	W

Note: P_D is measured at T_a= 25°C



Electrical Characteristics

CY7530-2, +3.0V Output Type

Parameter	Symbol	Test Conditions		Min.	Typ.	Max.	Unit
		V _{IN}	Conditions				
Output Voltage	V _{OUT}	8V	I _{OUT} =10mA	2.940	3.000	3.060	V
Output Current	I _{OUT}	6V	-	-	200	-	mA
Load Regulation	ΔV _{OUT}	8V	1mA ≤ I _{OUT} ≤ 20mA	-	40	60	mV
Voltage Drop(Note)	V _{DIF}	-	I _{OUT} =1mA ΔV _{OUT} =2%	-	10	-	mV
Current Consumption	I _{SS}	8V	No load	-	2.0	5.0	μA
Line Regulation	$\frac{V_{OUT}}{V_{IN}}$	-	4V ≤ V _{IN} ≤ 35V I _{OUT} =1mA	-	0.3	-	%/V
Input Voltage	V _{IN}	-	-	-	-	35	V
Temperature Coefficient	$\frac{V_{OUT}}{T_a}$	8V	I _{OUT} =10mA 0°C < T _a < 70°C	-	±0.12	-	mV/°C

Note: Dropout voltage is defined as the input voltage minus the output voltage that produces a 2% change in the output voltage from the value at V_{IN} = V_{OUT}+2V with a fixed load.

CY7533-2, +3.3V Output Type

Parameter	Symbol	Test Conditions		Min.	Typ.	Max.	Unit
		V _{IN}	Conditions				
Output Voltage	V _{OUT}	8V	I _{OUT} =10mA	3.234	3.300	3.366	V
Output Current	I _{OUT}	6.3V	-	-	200	-	mA
Load Regulation	ΔV _{OUT}	8V	1mA ≤ I _{OUT} ≤ 20mA	-	40	60	mV
Voltage Drop(Note)	V _{DIF}	-	I _{OUT} =1mA ΔV _{OUT} =2%	-	10	-	mV
Current Consumption	I _{SS}	8V	No load	-	2.0	5.0	μA
Line Regulation	$\frac{V_{OUT}}{V_{IN}}$	-	4.5V ≤ V _{IN} ≤ 35V I _{OUT} =1mA	-	0.3	-	%/V
Input Voltage	V _{IN}	-	-	-	-	35	V
Temperature Coefficient	$\frac{V_{OUT}}{T_a}$	8V	I _{OUT} =10mA 0°C < T _a < 70°C	-	±0.12	-	mV/°C

Note: Dropout voltage is defined as the input voltage minus the output voltage that produces a 2% change in the output voltage from the value at V_{IN} = V_{OUT}+2V with a fixed load.



CY7536-2, +3.6V Output Type

Parameter	Symbol	Test Conditions		Min.	Typ.	Max.	Unit
		V _{IN}	Conditions				
Output Voltage	V _{OUT}	8V	I _{OUT} =10mA	3.528	3.600	3.672	V
Output Current	I _{OUT}	6.6V	-	-	200	-	mA
Load Regulation	ΔV _{OUT}	8V	1mA ≤ I _{OUT} ≤ 20mA	-	40	60	mV
Voltage Drop(Note)	V _{DIF}	-	I _{OUT} =1mA ΔV _{OUT} =2%	-	10	-	mV
Current Consumption	I _{SS}	8V	No load	-	2.0	5.0	μA
Line Regulation	$\frac{V_{OUT}}{V_{IN}} \frac{V_{OUT}}{V_{OUT}}$	-	4.6V ≤ V _{IN} ≤ 35V I _{OUT} =1mA	-	0.3	-	%/V
Input Voltage	V _{IN}	-	-	-	-	35	V
Temperature Coefficient	$\frac{V_{OUT}}{T_a}$	8V	I _{OUT} =10mA 0°C < T _a < 70°C	-	±0.12	-	mV/°C

Note: Dropout voltage is defined as the input voltage minus the output voltage that produces a 2% change in the output voltage from the value at V_{IN} = V_{OUT}+2V with a fixed load.

CY7544-2, +4.4V Output Type

Parameter	Symbol	Test Conditions		Min.	Typ.	Max.	Unit
		V _{IN}	Conditions				
Output Voltage	V _{OUT}	8V	I _{OUT} =10mA	4.312	4.400	4.488	V
Output Current	I _{OUT}	7.4V	-	-	200	-	mA
Load Regulation	ΔV _{OUT}	8V	1mA ≤ I _{OUT} ≤ 20mA	-	40	60	mV
Voltage Drop(Note)	V _{DIF}	-	I _{OUT} =1mA ΔV _{OUT} =2%	-	10	-	mV
Current Consumption	I _{SS}	8V	No load	-	2.0	5.0	μA
Line Regulation	$\frac{V_{OUT}}{V_{IN}} \frac{V_{OUT}}{V_{OUT}}$	-	5.4V ≤ V _{IN} ≤ 35V I _{OUT} =1mA	-	0.3	-	%/V
Input Voltage	V _{IN}	-	-	-	-	35	V
Temperature Coefficient	$\frac{V_{OUT}}{T_a}$	8V	I _{OUT} =10mA 0°C < T _a < 70°C	-	±0.12	-	mV/°C

Note: Dropout voltage is defined as the input voltage minus the output voltage that produces a 2% change in the output voltage from the value at V_{IN} = V_{OUT}+2V with a fixed load.



CY7550-2, +5.0V Output Type

Parameter	Symbol	Test Conditions		Min.	Typ.	Max.	Unit
		V _{IN}	Conditions				
Output Voltage	V _{OUT}	8V	I _{OUT} =10mA	4.900	5.000	5.100	V
Output Current	I _{OUT}	8V	-	-	200	-	mA
Load Regulation	ΔV _{OUT}	8V	1mA ≤ I _{OUT} ≤ 20mA	-	40	60	mV
Voltage Drop(Note)	V _{DIF}	-	I _{OUT} =1mA ΔV _{OUT} =2%	-	10	-	mV
Current Consumption	I _{SS}	8V	No load	-	2.0	5.0	μA
Line Regulation	$\frac{V_{OUT}}{V_{IN}} \frac{V_{OUT}}{V_{OUT}}$	-	6V ≤ V _{IN} ≤ 35V I _{OUT} =1mA	-	0.3	-	%/V
Input Voltage	V _{IN}	-	-	-	-	35	V
Temperature Coefficient	$\frac{V_{OUT}}{T_a}$	8V	I _{OUT} =10mA 0°C < T _a < 70°C	-	±0.12	-	mV/°C

Note: Dropout voltage is defined as the input voltage minus the output voltage that produces a 2% change in the output voltage from the value at V_{IN} = V_{OUT}+2V with a fixed load.

Application Circuits

Basic Circuits

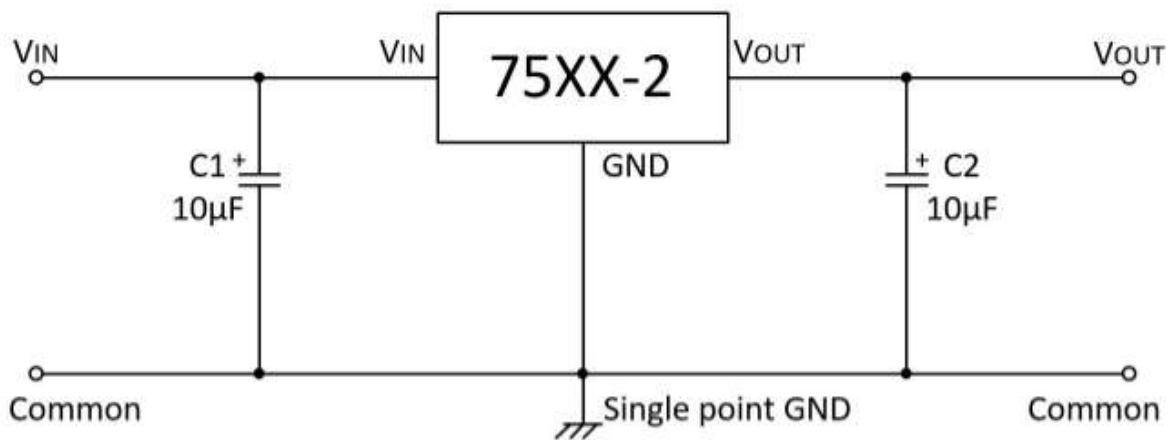

Package Information (T092)

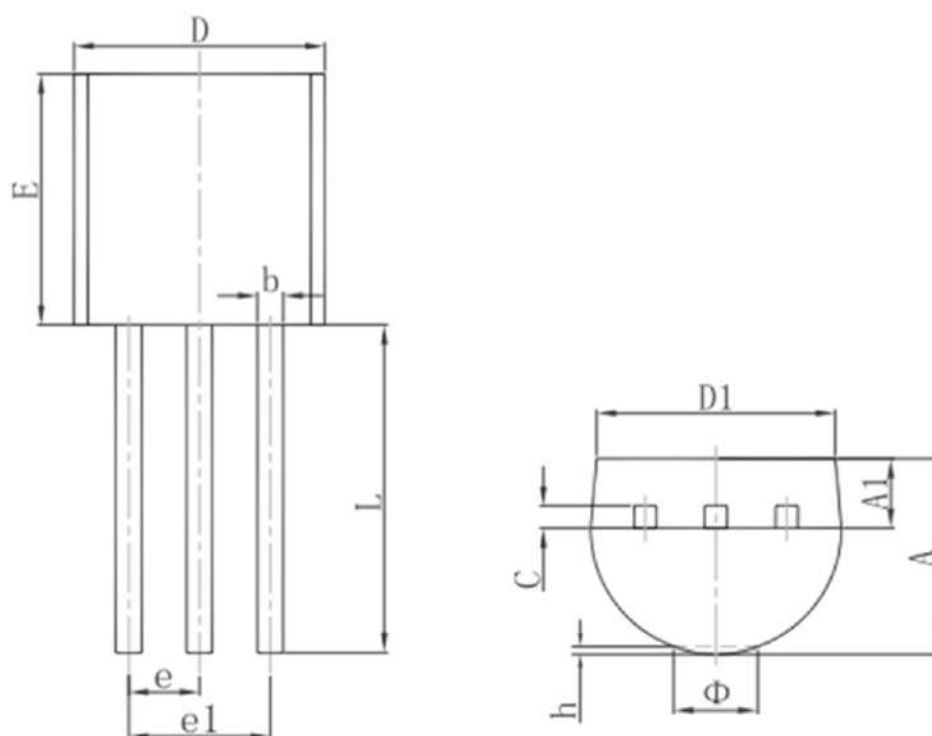

Symbol	Dimensions In Millimeters		Dimensions In Inches	
	Min.	Max.	Min.	Max.
A	3.300	3.700	0.130	0.146
A1	1.100	1.400	0.043	0.055
b	0.380	0.550	0.015	0.022
c	0.360	0.510	0.014	0.020
D	4.300	4.700	0.169	0.185
D1	3.430		0.135	
E	4.300	4.700	0.169	0.185
e	1.270TYP.		0.050TYP.	
e1	2.440	2.640	0.096	0.104
L	14.100	14.500	0.555	0.571
Φ		1.600		0.063
h	0.000	0.380	0.000	0.015

Package Information (SOT89)

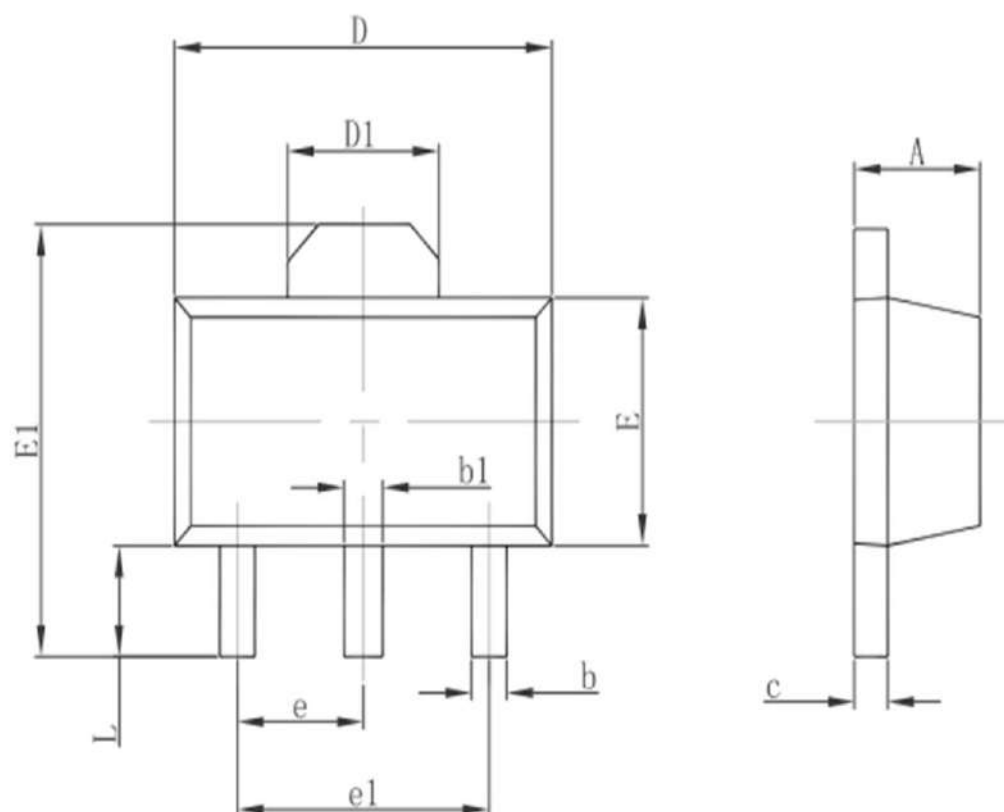

Symbol	Dimensions In Millimeters		Dimensions In Inches	
	Min.	Max.	Min.	Max.
A	1.400	1.600	0.055	0.063
b	0.320	0.520	0.013	0.020
b1	0.400	0.580	0.016	0.023
c	0.350	0.440	0.014	0.017
D	4.400	4.600	0.173	0.181
D1	1.550REF.		0.061REF.	
E	2.300	2.600	0.091	0.102
E1	3.940	4.250	0.155	0.167
e	1.500TYP.		0.060TYP.	
e1	3.000TYP.		0.118TYP.	
L	0.900	1.200	0.035	0.047

Package Information (SOT23-3)

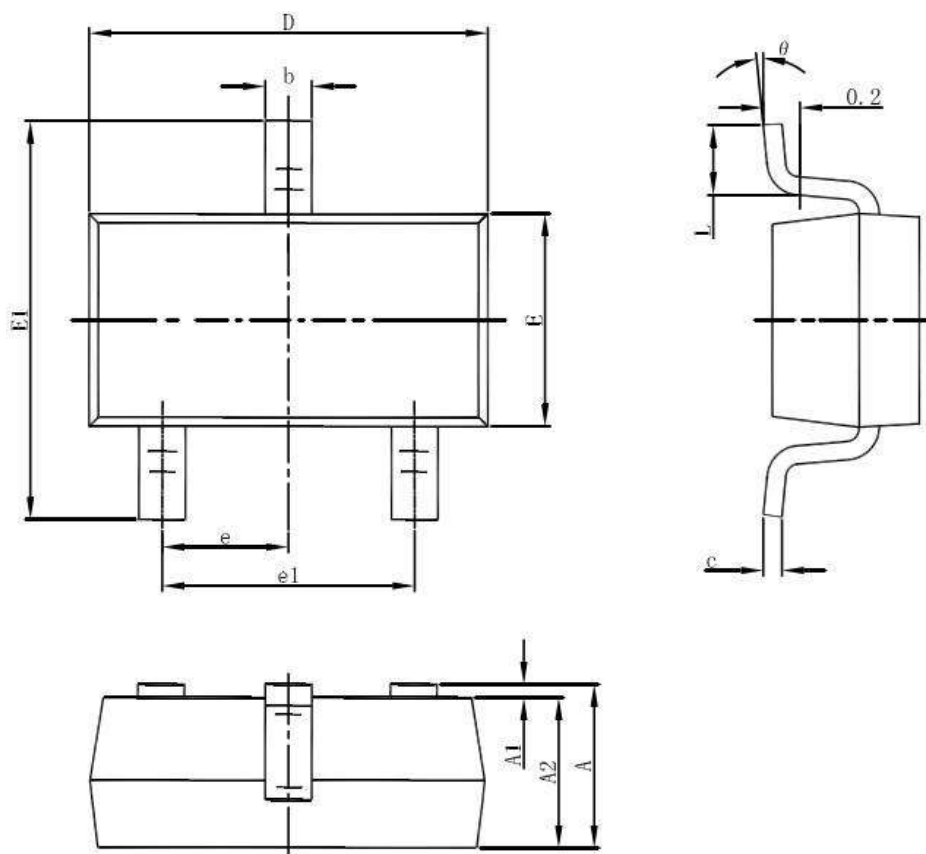

Symbol	Dimensions In Millimeters		Dimensions In Inches	
	Min.	Max.	Min.	Max.
A	1.050	1.250	0.041	0.049
A1	0.000	0.100	0.000	0.004
A2	1.050	1.150	0.041	0.045
b	0.300	0.500	0.012	0.020
c	0.100	0.200	0.004	0.008
D	2.820	3.020	0.111	0.119
E	1.500	1.700	0.059	0.067
E1	2.650	2.950	0.104	0.116
e	0.950(BSC)		0.037(BSC)	
e1	1.800	2.000	0.071	0.079
L	0.300	0.600	0.012	0.024
θ	0°	8°	0°	8°



Special Instructions

The company reserves the right of final interpretation of this specification.

Version Change Description

Version: V2.0
2021.11.3

Author: Yangyang

Time:

Modify the record:

1. Re-typesetting the manual and checking some data
-