

250mA、 12V、 LDO

CYP6201

General Description

The CYP6201 series is a group of positive voltage output, three-pin regulators, that provide a high current even when the input/output voltage differential is small. Low power consumption and high accuracy is achieved through CMOS and laser trimming technologies.

The CYP6201 consists of a high-precision voltage reference, an error amplification circuit, and a current limited output driver. Transient response to load variations have improved in comparison to the existing series. SOT-89-3L packages is available.

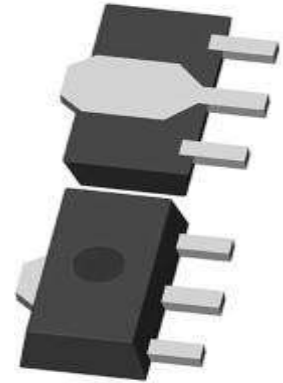

Features

- Low voltage drop: 0.17V@100mA
- High input voltage: 12V
- Low temperature coefficient
- MAX Output Current: 0.5A
- Low Quiescent Current: 2.0uA
- Output voltage accuracy: tolerance $\pm 2\%$
- Built-in current limiter
- SOT-89-3L package

Applications

- Battery-powered equipment
- Hand-Hold Equipment
- GPS Receivers
- Wireless LAN

Order information

Device	Package	Packaging style	SPQ
CYP6201Pxx2P R	SOT89-3L	Reel	1000

Order Information
CYP6201P①②③④⑤

Designator	Symbol	Description
① ②	Integer	Output Voltage(2.1V~5.0V)
③	2	Output voltage accuracy: tolerance $\pm 2\%$
④	P	Package:SOT-89-3L
⑤	R	RoHS / Pb Free
	G	Halogen Free

Note: "①②" stands for output voltages. Other voltages can be specially customized

Selection Table

Part No.	Output Voltage	Package	Marking
CYP6201P302P R	3.0V	SOT-89-3L	130N
CYP6201P332P R	3.3V		133N
CYP6201P402P R	4.0V		140N
CYP6201P452P R	4.5V		145N
CYP6201P502P R	5.0V		150N

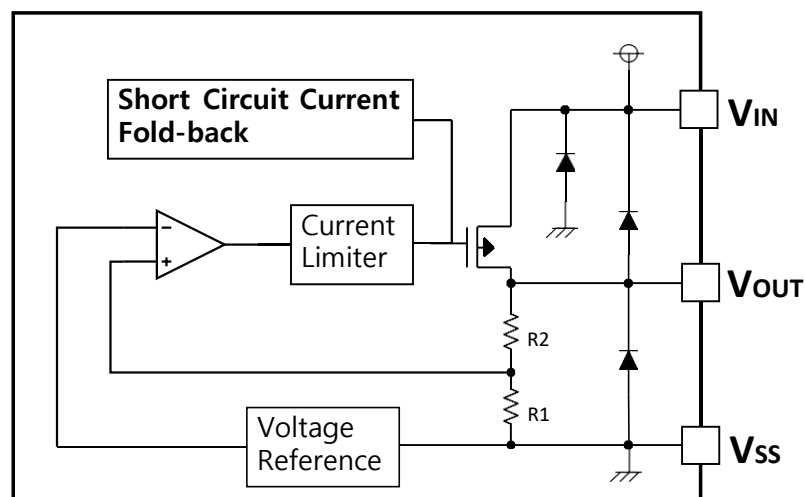
Block Diagram

Pin Assignment

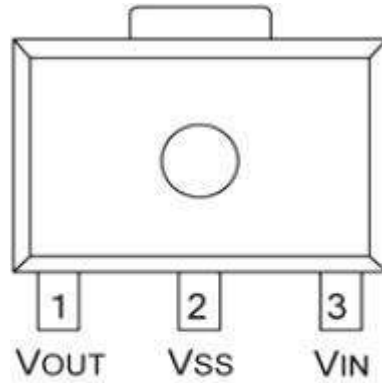

**SOT-89
(TOP VIEW)**

Typical Application

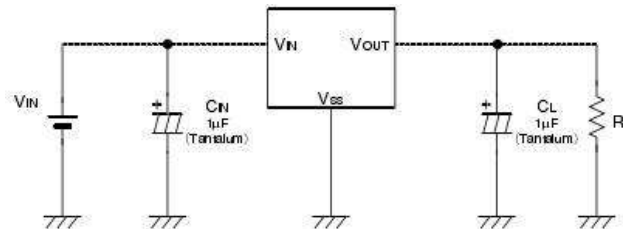

Note1: Input capacitor $C_{IN}=1\mu F$.

Note2: Output capacitor $C_{OUT}=1\mu F/6.8\mu F$ (1uF Tantalum capacitor or 6.8uF ceramic capacitor is recommended).

Absolute Maximum Ratings

Parameter	Symbol	Min.	Max.	Unit
Supply Voltage	Vin	-0.3	15	V
Operating Temperature		-40	+85	°C
Storage Temperature		-40	+125	°C

Note: These are stress ratings only. Stresses exceeding the range specified under “Absolute Maximum Ratings” may cause substantial damage to the device. Functional operation of this device at other conditions beyond those listed in the specification is not implied and prolonged exposure to extreme conditions may affect device reliability.



Electrical Characteristics

CYP6201 for any output voltage

(Ta=25°C)

Parameter	Symbol	Conditions	Min.	Typ.	Max.	Unit
Output Voltage	Vout	Vin=Vout+1V 1.0mA≤Iout≤30mA	Vout×0.98	--	Vout×1.02	V
Output Current	Iout	Vin-Vout=1V	--	250	500	mA
Low dropout	Vdrop	Refer to the next table				
Line Regulation	$\frac{\Delta V_{OUT}}{\Delta V_{IN} \times V_{OUT}}$	1.6V≤Vin≤8V Iout=100mA	--	0.05	0.2	%/V
Load Regulation	Δ Vout	Vin= Vout+1V 1.0mA≤Iout≤100mA	--	12	30	mV
Output voltage Temperature Coefficiency	$\frac{\Delta V_{OUT}}{\Delta Ta}$	Iout=30mA 0°C≤Ta≤70°C	--	±100	--	PPM /°C
PSRR	PSRR	F=1KHz Vin=Vout+1V	--	40	--	dB
Supply Current	Issl	--	--	2	--	uA
Input Voltage	Vin	--	--	--	15	V

Electrical Characteristics by Output Voltage:

Output Voltage Vout(V)	Dropout Voltage Vdif (V)		
	Conditions	Typ.	Max.
Vout ≤ 2.0V	Iout=60 mA	0.1	0.12
2.0 < Vout ≤ 3.0	Iout=80 mA	0.12	0.14
3.0 < Vout ≤ 4.0	Iout=100 mA	0.16	0.18
4.0 < Vout ≤ 5.0		0.17	0.18
3.0 < Vout ≤ 4.0	Iout=200 mA	0.21	0.24
4.0 < Vout ≤ 14.0		0.20	0.22
3.0 < Vout ≤ 4.0	Iout=500 mA	0.7	0.75
4.0 < Vout ≤ 14.0		0.72	0.76

Typical Performance Characteristics

(1) Output Voltage vs Input Voltage and Output Voltage vs Output Current and Input Transient Response

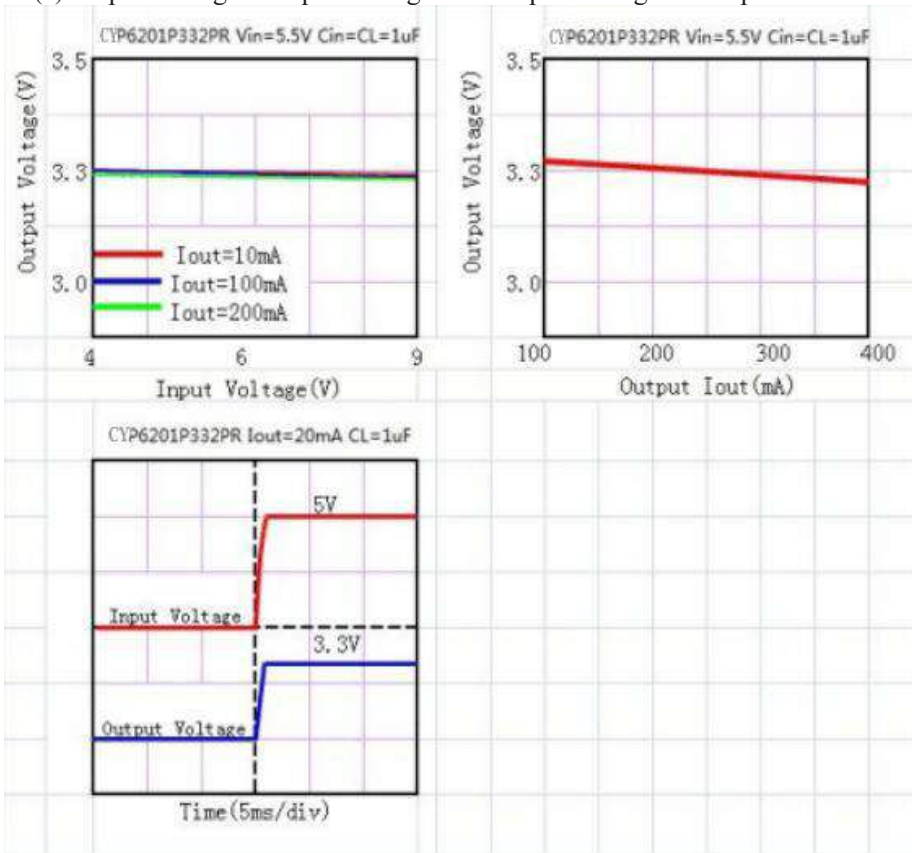

(2) Output Voltage vs Ambient Temperature

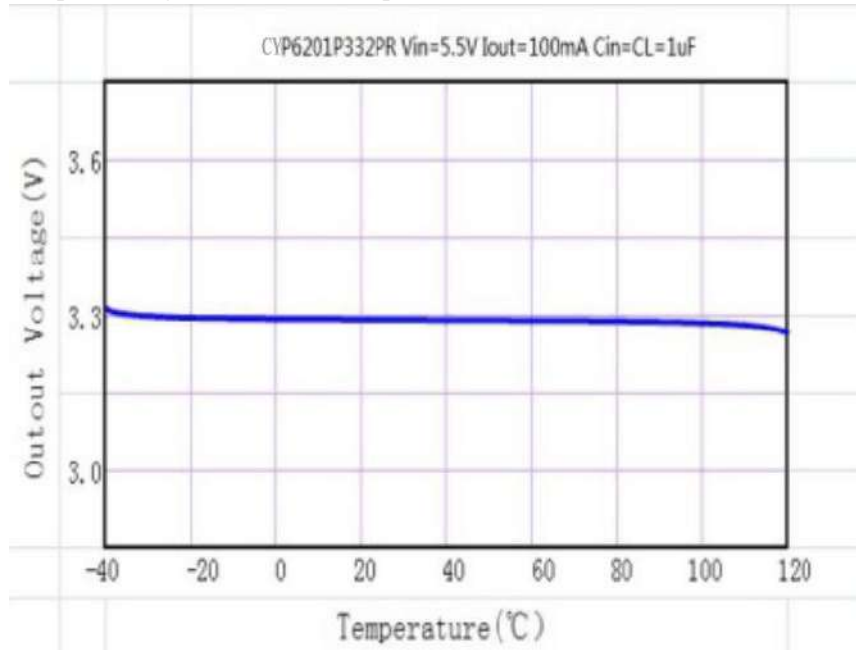

Package Information
3-pin SOT-89-3L Outline Dimensions

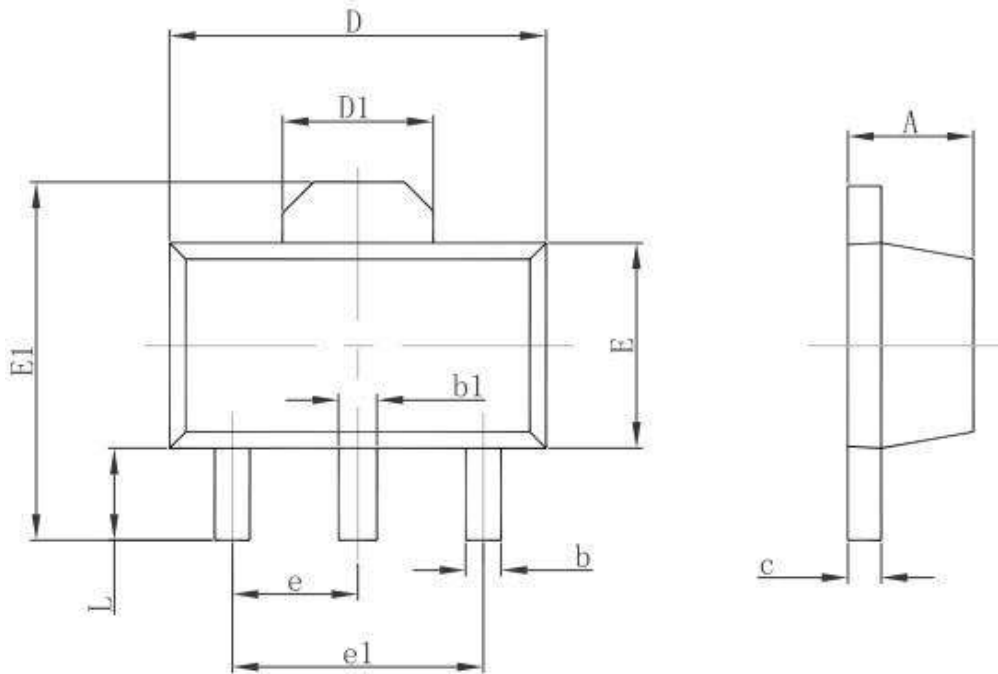

Symbol	Dimensions In Millimeters		Dimensions In Inches	
	Min.	Max.	Min.	Max.
A	1.400	1.600	0.055	0.063
b	0.320	0.520	0.013	0.020
b1	0.400	0.580	0.016	0.023
c	0.350	0.440	0.014	0.017
D	4.400	4.600	0.173	0.181
D1	1.550 REF.		0.061 REF.	
E	2.300	2.600	0.091	0.102
E1	3.940	4.250	0.155	0.167
e	1.500 TYP.		0.060 TYP.	
e1	3.000 TYP.		0.118 TYP.	
L	0.900	1.200	0.035	0.047

Special Version

The company reserves the right of final interpretation of this specification.

Version Change Description

Versions: V1.7

Writer: Xin CHun Li

Time: 2021.10.15

Amendant record:

- 1.Re-typesetting the manual and checking some data