

Low Power Voltage Detector

CYP61C series

General Description

The CYP61C series devices are a set of three terminal low power voltage detectors implemented in CMOS technology. Each voltage detector in the series detects a particular fixed voltage ranging from 0.9V to 5.0V. The voltage detectors consist of a high-precision and low power consumption standard voltage source as well as a comparator, hysteresis circuit, and an output driver (CMOS inverter or NMOS open drain). CMOS technology ensures low power consumption. Although designed primarily as fixed voltage detectors, these devices can be used with external components to detect user specified threshold voltages.



Features

- Low power consumption
- Low temperature coefficient
- Built-in hysteresis characteristic
- High input voltage (up to 8V)
- Output voltage accuracy: tolerance $\pm 1\%$ or $\pm 2\%$
- SOT23-3 and SOT23 package

Applications

- Battery checkers
- Level selectors
- Power failure detectors
- Microcomputer reset
- Battery memory backup
- Non-volatile RAM signal storage protectors



Order specification

Part No	Output	Detectable Voltage	Tolerance	Package	Devices per reel
CYP61CC0901MR	CMOS	0.9V	±1%	SOT23-3 SOT23	3000PCS
CYP61CN0901MR	NMOS	0.9V	±1%		
CYP61CC0902MR	CMOS	0.9V	±2%		
CYP61CN0902MR	NMOS	0.9V	±2%		
...		
CYP61CC2501MR	CMOS	2.5V	±1%		
CYP61CN2501MR	NMOS	2.5V	±1%		
CYP61CC2502MR	CMOS	2.5V	±2%		
CYP61CN2502MR	NMOS	2.5V	±2%		
...		
CYP61CC2801MR	CMOS	2.8V	±1%		
CYP61CN2801MR	NMOS	2.8V	±1%		
CYP61CC2802MR	CMOS	2.8V	±2%		
CYP61CN2802MR	NMOS	2.8V	±2%		
...		
CYP61CC3001MR	CMOS	3.0V	±1%		
CYP61CN3001MR	NMOS	3.0V	±1%		
CYP61CC3002MR	CMOS	3.0V	±2%		
CYP61CN3002MR	NMOS	3.0V	±2%		
...		
CYP61CC5001MR	CMOS	5.0V	±1%		
CYP61CN5001MR	NMOS	5.0V	±1%		
CYP61CC5002MR	CMOS	5.0V	±2%		
CYP61CN5002MR	NMOS	5.0V	±2%		

Note:CYP61C①②③④⑤⑥⑦

Designator	Symbol	Description
①	C	CMOS output
	N	NMOS output
②③	VOUT	Output Voltage(0.9~5.0V) The stepping value:0.1V
④⑤	02	±2% accuracy
	01	±1% accuracy
⑥	M	Package:SOT23-3
	N	Package:SOT23
⑦	R	RoHS / Pb Free
	G	Halogen Free

Marking rule

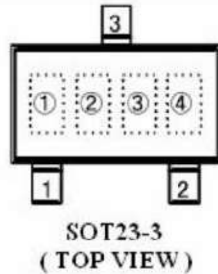

① Represents integer of detect voltage and

CMOS Output

MAR K	CONFIGURATIO N	VOLTAGE(V)
A	CMOS	0.X
B	CMOS	1.X
C	CMOS	2.X
D	CMOS	3.X
E	CMOS	4.X
F	CMOS	5.X
H	CMOS	6.X

N-Channel Open Drain Output

MAR K	CONFIGURATIO N	VOLTAGE(V)
K	N-ch	0.X
L	N-ch	1.X
M	N-ch	2.X
N	N-ch	3.X
P	N-ch	4.X
R	N-ch	5.X
S	N-ch	6.X

② Represents decimal number of detect voltage

MARK	VOLTAGE(V)	MARK	VOLTAGE(V)
0	X.0	5	X.5
1	X.1	6	X.6
2	X.2	7	X.7
3	X.3	8	X.8
4	X.4	9	X.9

③ Represents accuracy

MARK	ACCURACY
3	2%
1	1%

④ Represents production lot number

Based on the internal standard. (G,I,J,O,Q,W excepted)

Block Diagram and Pin Arrangement Diagram

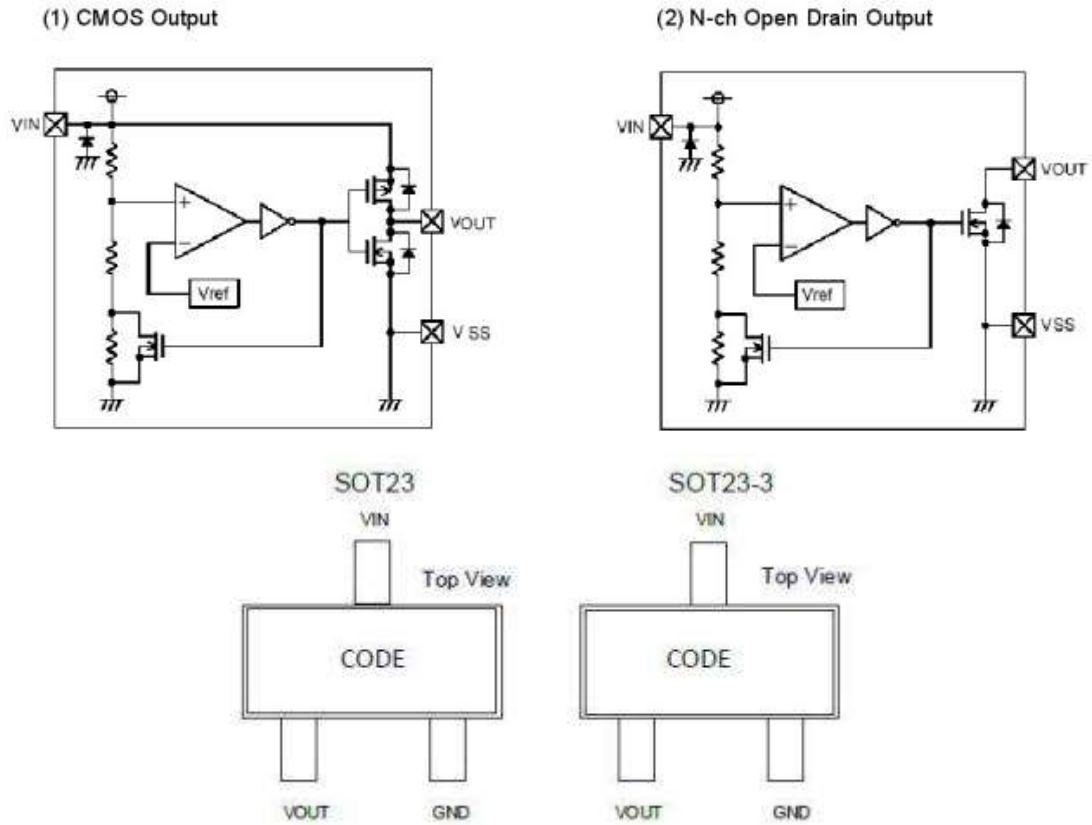

Pin Assignment

Pin No.	Pin Name	Description
1	VOUT	Output.
2	GND	Ground connection.
3	VIN	Supply Voltage Input.

Output Table & Curve

V_{DD}	$V_{DD} > V_{DET}(+)$	$V_{DD} \leq V_{DET}(-)$
V_{OUT}	Hi-Z	V_{SS}

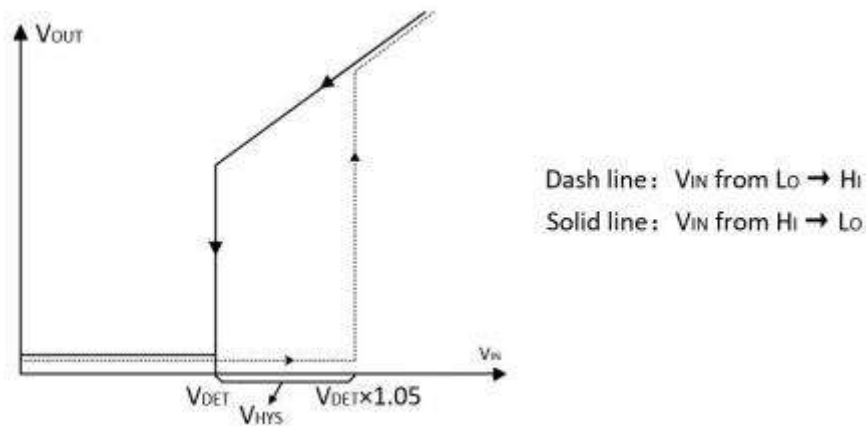

Functional Description

The CYP61C series devices are a set of three terminal low power voltage detectors implemented in CMOS technology. Each voltage detector in the series detects a particular fixed voltage ranging from 0.9V to 5.0V.

Absolute Maximum Ratings

Parameter	Symbol	Value	Unit
Supply Voltage Input	V_{IN}	-0.3~8.0	V
Operating Temperature	T_{amb}	-30~80	°C
Storage Temperature	T_{stg}	-50~125	°C

Note: These are stress ratings only. Stresses exceeding the range specified under "Absolute Maximum Ratings" may cause substantial damage to the device. prolonged exposure to extreme conditions may affect device reliability.

Thermal Information

Parameter	Symbol	Package	Max.	Unit
Thermal Resistance (Junction to Ambient) (Assume no ambient airflow, no heat sink)	θ_{JA}	SOT23-3	250	°C/W
Power Dissipation	P_D		0.20	W



Electrical Characteristics

Parameter	Symbol	Test Conditions		Min.	Typ.	Max.	Unit
Detection Voltage	VDET	VDF=0.8V~5.0V		VDF* 0.98	VDF	VDF* 1.02	V
Hysteresis Width	VHYS	-		0.02* VDET	0.05* VDET	0.10* VDET	V
Operating Current	IDD	Vin=1.5V		-	0.7	2.3	μA
		Vin=2.0V		-	0.8	2.7	
		Vin=3.0V		-	0.9	3.0	
		Vin=4.0V		-	1.0	3.2	
		Vin=5.0V		-	1.1	3.6	
Operating Voltage	VDD	-		0.7	-	10	V
Output Sink Current	IOL	2V	VOUT=0.2V	0.5	1	-	mA
Temperature Coefficient	$\frac{\Delta V_{DET}}{V_{DF} \Delta T_a}$	-25°C < Ta < 125°C		-	±100	-	ppm/ °C

Typical Performance Characteristics

(1) Output Voltage vs Input voltage

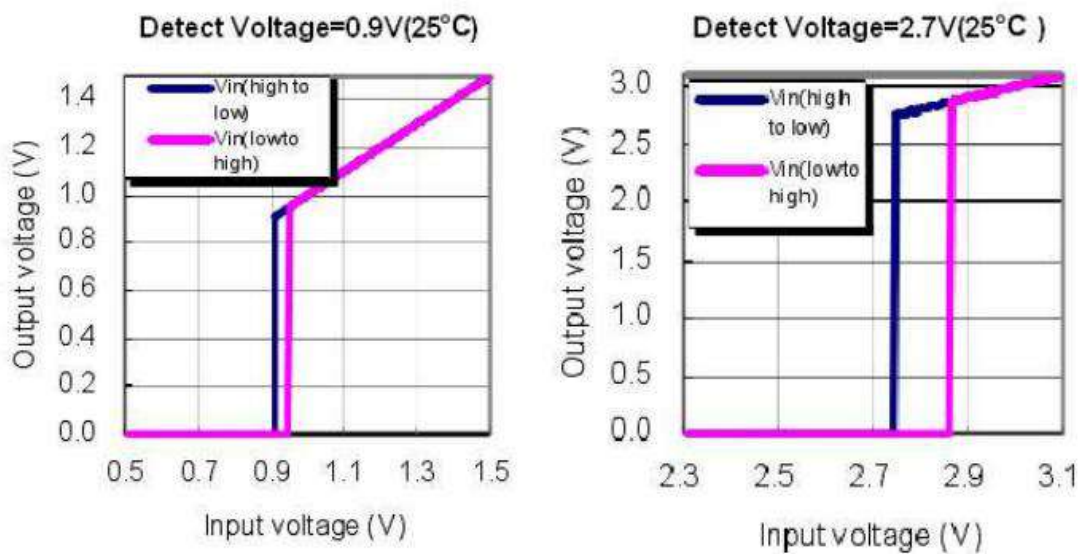

(2) Supply Current vs. Input Voltage

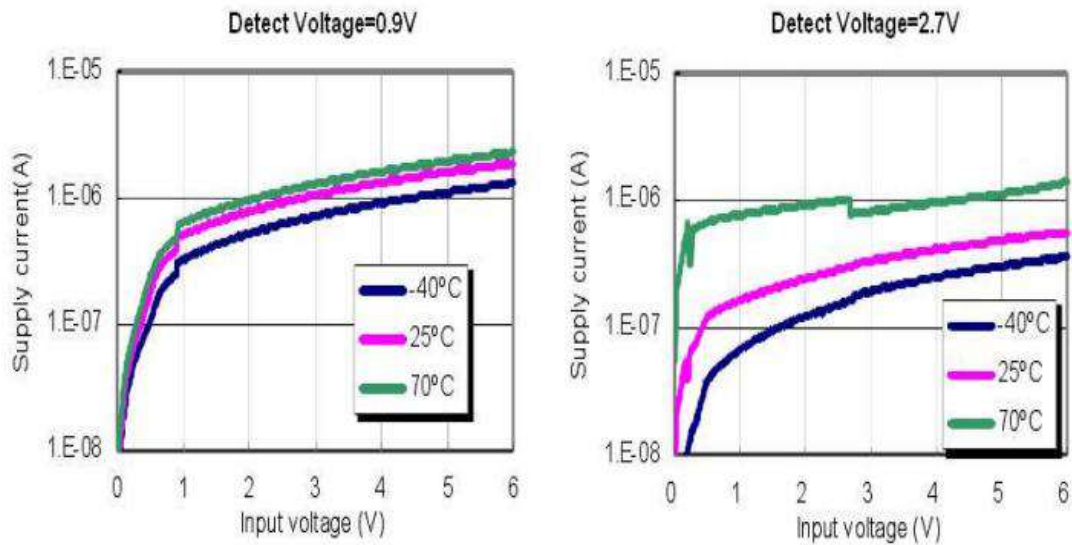

Application Circuits

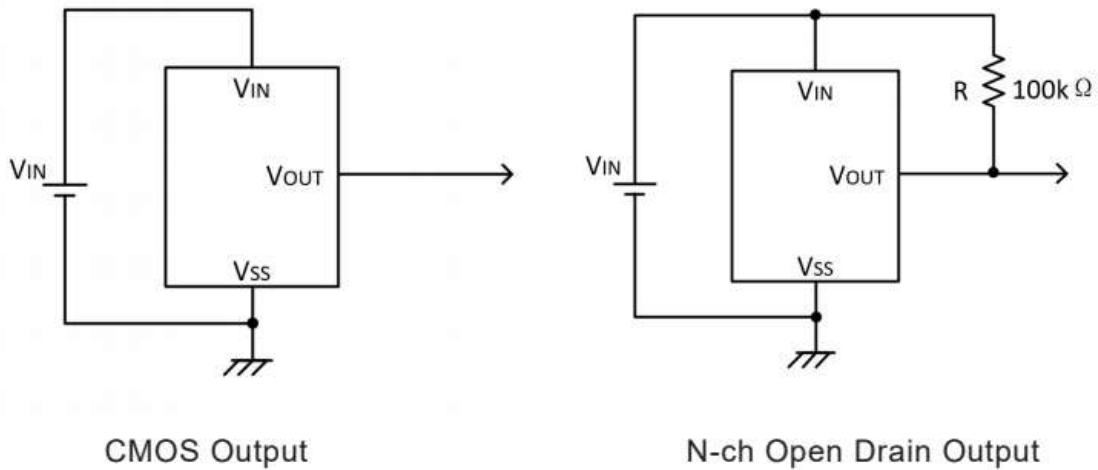

Microcomputer Reset Circuit

Normally a reset circuit is required to protect the microcomputer system from malfunctions due to power line interruptions. The following examples show how different output configurations perform a reset function in various systems.

NMOS open drain output application for separate power supply:

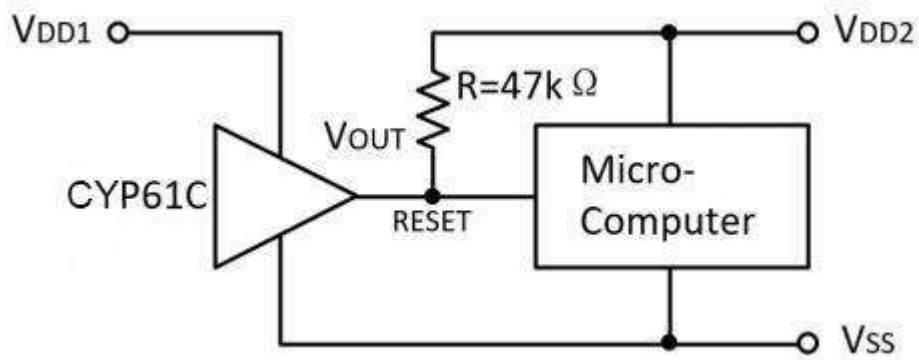

NMOS open drain output application with R-C delay:

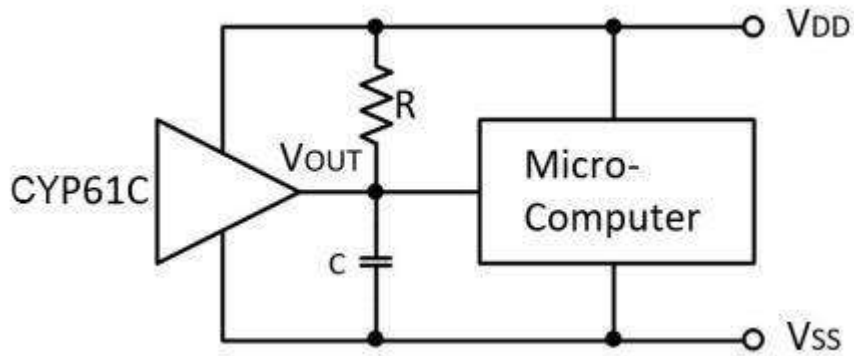

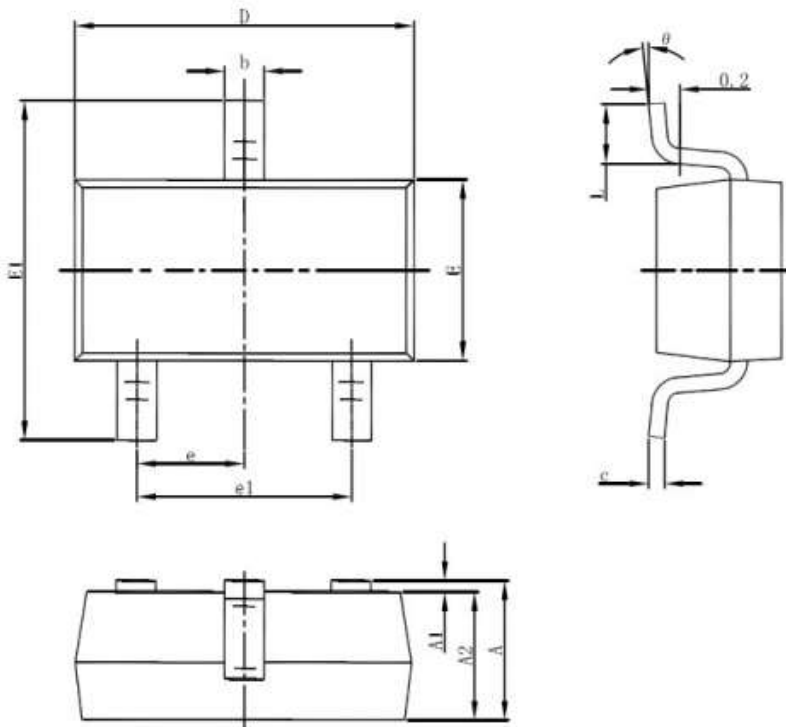
Package Information (SOT23-3)

Symbol	Dimensions In Millimeters		Dimensions In Inches	
	Min.	Max.	Min.	Max.
A	1.050	1.250	0.041	0.049
A1	0.000	0.100	0.000	0.004
A2	1.050	1.150	0.041	0.045
b	0.300	0.500	0.012	0.020
c	0.100	0.200	0.004	0.008
D	2.820	3.020	0.111	0.119
E	1.500	1.700	0.059	0.067
E1	2.650	2.950	0.104	0.116
e	0.950(BSC)		0.037(BSC)	
e1	1.800	2.000	0.071	0.079
L	0.300	0.600	0.012	0.024
θ	0°	8°	0°	8°

Package Information (SOT23)

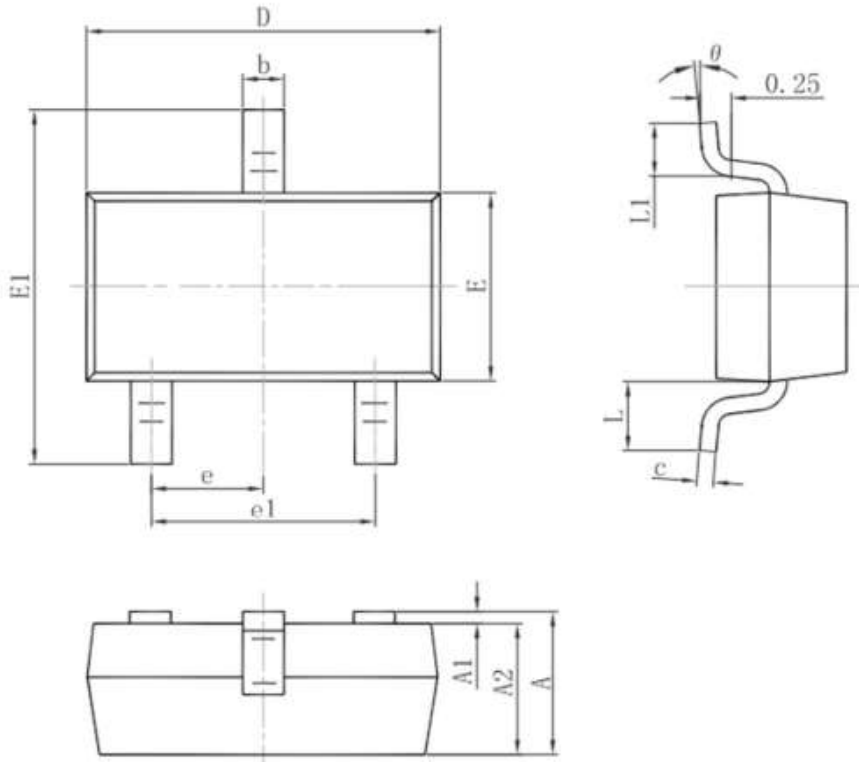

Symbol	Dimensions In Millimeters		Dimensions In Inches	
	Min.	Max.	Min.	Max.
A	0.900	1.150	0.035	0.045
A1	0.000	0.100	0.000	0.004
A2	0.900	1.050	0.035	0.041
b	0.300	0.500	0.012	0.020
c	0.080	0.150	0.003	0.006
D	2.800	3.000	0.110	0.118
E	1.200	1.400	0.047	0.055
E1	2.250	2.550	0.089	0.100
e	0.950TYP.		0.037TYP.	
e1	1.800	2.000	0.071	0.079
L	0.550REF.		0.022REF.	
L1	0.300	0.500	0.012	0.020
θ	0°	8°	0°	8°