

Low Power Voltage Detector

CY70xxA-1

General Description

The CY70XXA-1 series devices are a set of three terminal low power voltage detectors implemented in CMOS technology. Each voltage detector in the series detects a particular fixed voltage ranging from 2.2V to 7.0V. The voltage detectors consist of a high precision and low power consumption standard voltage source as well as a comparator, hysteresis circuit, and an output driver. CMOS technology ensures low power consumption.

Although designed primarily as fixed voltage detectors, these devices can be used with external components to detect user specified threshold voltages.



Features

- Low power consumption
- Low temperature coefficient
- Built-in hysteresis characteristic
- High input voltage (up to 15V)
- Output voltage accuracy: tolerance $\pm 1\%$ or $\pm 2\%$
- TO92, SOT89, SOT23 and SOT23-3 package

Applications

- Battery checkers
- Level selectors
- Power failure detectors
- Microcomputer reset
- Battery memory backup
- Non-volatile RAM signal storage protectors

**Order specification**

Part No	Detectable Voltage	Hysteresis Width	Tolerance
CY7022A-1	2.2V	0.11V	±2%
CY7024A-1	2.4V	0.12V	±2%
CY7027A-1	2.7V	0.135V	±2%
CY7030A-1	3.0V	0.15V	±2%
CY7033A-1	3.3V	0.165V	±2%
CY7036A-1	3.6V	0.18V	±2%
CY7039A-1	3.9V	0.195V	±2%
CY7040A-1	4.0V	0.2V	±2%
CY7044A-1	4.4V	0.22V	±2%
CY7050A-1	5.0V	0.25V	±2%
CY7070A-1	7.0V	0.35V	±2%

Package	Manner of Packing	Devices per bag/reel
TO92	Bag	1000PCS/bag
SOT89	Reel	1000PCS/reel
SOT23-3	Reel	3000PCS/reel
SOT23	Reel	3000PCS/reel

Note:H70①②A-1③④⑤

Designator	Symbol	Description
①②	Integer	Output Voltage(2.2~7.0V)
③	N	NMOS
	C	CMOS
④	T	Package:TO-92
	P	Package:SOT89
	M	Package:SOT23-3
	N	Package:SOT23
⑤	R	RoHS / Pb Free
	G	Halogen Free

Block Diagram and Pin Arrangement Diagram

(1) CMOS Output

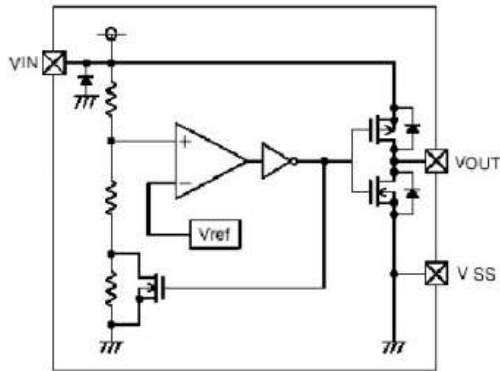

(2) N-ch Open Drain Output

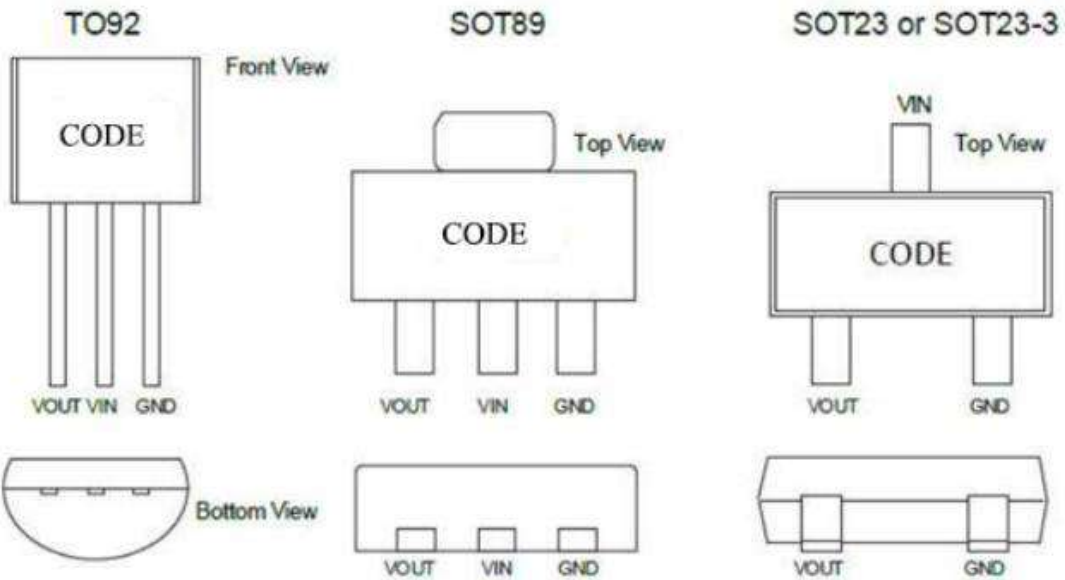
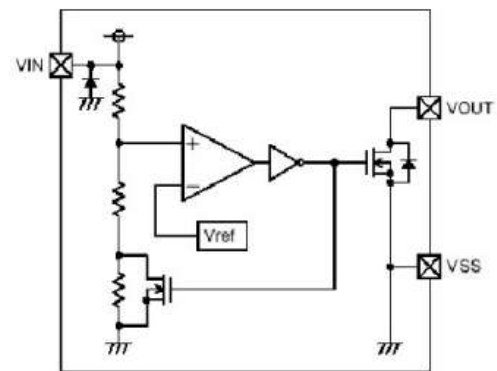

Pin Assignment

Pin No.	Pin Name	Description
1	VOUT	Output.
2	VIN	Supply Voltage Input.
3	GND	Ground connection.

Output Table & Curve



CY70XXA-1

V_{DD}	$V_{DD} > V_{DET}(+)$	$V_{DD} \leq V_{DET}(-)$
V_{OUT}	Hi-Z	V_{SS}

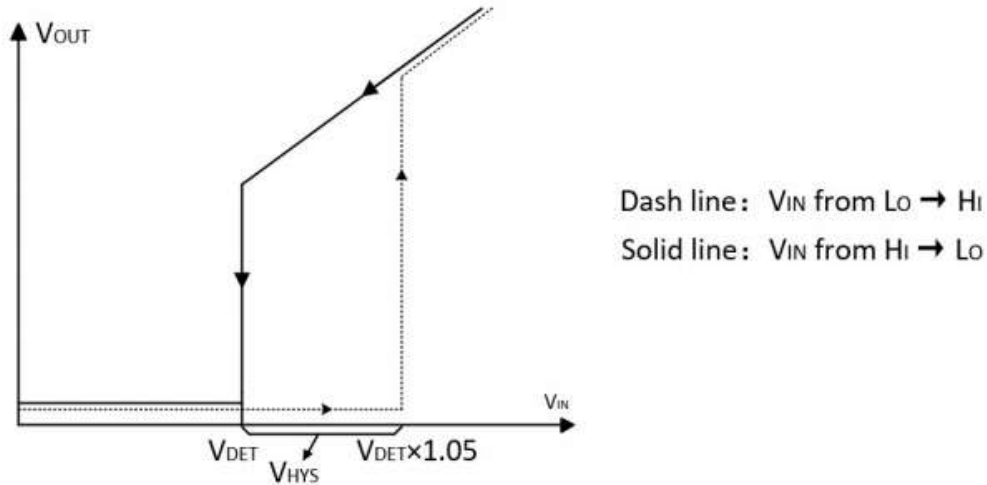

Functional Description

The CY70XXA-1 series devices are a set of three terminal low power voltage detectors implemented in CMOS technology. Each voltage detector in the series detects a particular fixed voltage ranging from 2.2V to 7.0V.

Absolute Maximum Ratings

Parameter	Symbol	Value	Unit
Supply Voltage Input	V_{IN}	-0.3~16	V
Operating Temperature	T_{amb}	-40~85	$^{\circ}C$
Storage Temperature	T_{stg}	-50~125	$^{\circ}C$

Note: These are stress ratings only. Stresses exceeding the range specified under “Absolute Maximum Ratings” may cause substantial damage to the device. prolonged exposure to extreme conditions may affect device reliability.

Thermal Information

Parameter	Symbol	Package	Max.	Unit
Thermal Resistance (Junction to Ambient) (Assume no ambient airflow, no heat sink)	θ_{JA}	SOT23	500	$^{\circ}C/W$
		SOT89	200	$^{\circ}C/W$
		TO92	200	$^{\circ}C/W$
Power Dissipation	P_D	SOT23	0.20	W
		SOT89	0.50	W
		TO92	0.50	W

**Electrical Characteristics**

CY7022A-1XXX, Ta=25°C

Parameter	Symbol	Test Conditions		Min.	Typ.	Max.	Unit
		V _{DD}	Conditions				
Detection Voltage	V _{DET}	-	-	2.156	2.200	2.244	V
Hysteresis Width	V _{HYS}	-	-	0.02* V _{DET}	0.05* V _{DET}	0.10* V _{DET}	V
Operating Current	I _{DD}	8V	No Load	-	2	3	μA
Operating Voltage	V _{DD}	-	-	1.5	-	16	V
Output Sink Current	I _{OL}	2V	V _{OUT} =0.2V	0.5	1	-	mA
Temperature Coefficient	$\frac{\Delta V_{DET}}{\Delta T_a}$	-	0°C <Ta<70°C	-	±0.9	-	mV/ °C

CY7024A-1XXX, Ta=25°C

Parameter	Symbol	Test Conditions		Min.	Typ.	Max.	Unit
		V _{DD}	Conditions				
Detection Voltage	V _{DET}	-	-	2.352	2.400	2.448	V
Hysteresis Width	V _{HYS}	-	-	0.02* V _{DET}	0.05* V _{DET}	0.10* V _{DET}	V
Operating Current	I _{DD}	8V	No Load	-	2	3	μA
Operating Voltage	V _{DD}	-	-	1.5	-	16	V
Output Sink Current	I _{OL}	2V	V _{OUT} =0.2V	0.5	1	-	mA
Temperature Coefficient	$\frac{\Delta V_{DET}}{\Delta T_a}$	-	0°C <Ta<70°C	-	±0.9	-	mV/ °C



CY70XXA-1

CY7027A-1XXX, Ta=25°C

Parameter	Symbol	Test Conditions		Min.	Typ.	Max.	Unit
		V _{DD}	Conditions				
Detection Voltage	V _{DET}	-	-	2.646	2.700	2.754	V
Hysteresis Width	V _{HYS}	-	-	0.02* V _{DET}	0.05* V _{DET}	0.10* V _{DET}	V
Operating Current	I _{DD}	8V	No Load	-	2	3	μA
Operating Voltage	V _{DD}	-	-	1.5	-	16	V
Output Sink Current	I _{OL}	2V	V _{OUT} =0.2V	0.5	1	-	mA
Temperature Coefficient	$\frac{\Delta V_{DET}}{\Delta T_a}$	-	0°C <Ta<70°C	-	±0.9	-	mV/ °C

CY7030A-1XXX, Ta=25°C

Parameter	Symbol	Test Conditions		Min.	Typ.	Max.	Unit
		V _{DD}	Conditions				
Detection Voltage	V _{DET}	-	-	2.940	3.000	3.060	V
Hysteresis Width	V _{HYS}	-	-	0.02* V _{DET}	0.05* V _{DET}	0.10* V _{DET}	V
Operating Current	I _{DD}	8V	No Load	-	2	3	μA
Operating Voltage	V _{DD}	-	-	1.5	-	16	V
Output Sink Current	I _{OL}	2V	V _{OUT} =0.2V	1.2	2.5	-	mA
Temperature Coefficient	$\frac{\Delta V_{DET}}{\Delta T_a}$	-	0°C <Ta<70°C	-	±0.9	-	mV/ °C



CY70XXA-1

CY7033A-1XXX, Ta=25°C

Parameter	Symbol	Test Conditions		Min.	Typ.	Max.	Unit
		V _{DD}	Conditions				
Detection Voltage	V _{DET}	-	-	3.234	3.300	3.366	V
Hysteresis Width	V _{HYS}	-	-	0.02* V _{DET}	0.05* V _{DET}	0.10* V _{DET}	V
Operating Current	I _{DD}	8V	No Load	-	2	3	μA
Operating Voltage	V _{DD}	-	-	1.5	-	16	V
Output Sink Current	I _{OL}	2V	V _{OUT} =0.2V	1.2	2.5	-	mA
Temperature Coefficient	$\frac{\Delta V_{DET}}{\Delta T_a}$	-	0°C <Ta<70°C	-	±0.9	-	mV/ °C

CY7036A-1XXX, Ta=25°C

Parameter	Symbol	Test Conditions		Min.	Typ.	Max.	Unit
		V _{DD}	Conditions				
Detection Voltage	V _{DET}	-	-	3.528	3.600	3.672	V
Hysteresis Width	V _{HYS}	-	-	0.02* V _{DET}	0.05* V _{DET}	0.10* V _{DET}	V
Operating Current	I _{DD}	8V	No Load	-	2	3	μA
Operating Voltage	V _{DD}	-	-	1.5	-	16	V
Output Sink Current	I _{OL}	2V	V _{OUT} =0.2V	1.2	2.5	-	mA
Temperature Coefficient	$\frac{\Delta V_{DET}}{\Delta T_a}$	-	0°C <Ta<70°C	-	±0.9	-	mV/ °C



CY70XXA-1

CY7039A-1XXX, Ta=25°C

Parameter	Symbol	Test Conditions		Min.	Typ.	Max.	Unit
		V _{DD}	Conditions				
Detection Voltage	V _{DET}	-	-	3.822	3.900	3.978	V
Hysteresis Width	V _{HYS}	-	-	0.02* V _{DET}	0.05* V _{DET}	0.10* V _{DET}	V
Operating Current	I _{DD}	8V	No Load	-	2	3	μA
Operating Voltage	V _{DD}	-	-	1.5	-	16	V
Output Sink Current	I _{OL}	2V	V _{OUT} =0.2V	1.2	2.5	-	mA
Temperature Coefficient	$\frac{\Delta V_{DET}}{\Delta T_a}$	-	0°C <Ta<70°C	-	±0.9	-	mV/ °C

CY7040A-1XXX, Ta=25°C

Parameter	Symbol	Test Conditions		Min.	Typ.	Max.	Unit
		V _{DD}	Conditions				
Detection Voltage	V _{DET}	-	-	3.920	4.000	4.080	V
Hysteresis Width	V _{HYS}	-	-	0.02* V _{DET}	0.05* V _{DET}	0.10* V _{DET}	V
Operating Current	I _{DD}	8V	No Load	-	2	3	μA
Operating Voltage	V _{DD}	-	-	1.5	-	16	V
Output Sink Current	I _{OL}	2V	V _{OUT} =0.2V	1.2	2.5	-	mA
Temperature Coefficient	$\frac{\Delta V_{DET}}{\Delta T_a}$	-	0°C <Ta<70°C	-	±0.9	-	mV/ °C



CY70XXA-1

CY7044A-1XXX, Ta=25°C

Parameter	Symbol	Test Conditions		Min.	Typ.	Max.	Unit
		V _{DD}	Conditions				
Detection Voltage	V _{DET}	-	-	4.312	4.400	4.488	V
Hysteresis Width	V _{HYS}	-	-	0.02* V _{DET}	0.05* V _{DET}	0.10* V _{DET}	V
Operating Current	I _{DD}	8V	No Load	-	2	3	μA
Operating Voltage	V _{DD}	-	-	1.5	-	16	V
Output Sink Current	I _{OL}	2V	V _{OUT} =0.2V	3	6	-	mA
Temperature Coefficient	$\frac{\Delta V_{DET}}{\Delta T_a}$	-	0°C <Ta<70°C	-	±0.9	-	mV/ °C

CY7050A-1XXX, Ta=25°C

Parameter	Symbol	Test Conditions		Min.	Typ.	Max.	Unit
		V _{DD}	Conditions				
Detection Voltage	V _{DET}	-	-	4.900	5.000	5.100	V
Hysteresis Width	V _{HYS}	-	-	0.02* V _{DET}	0.05* V _{DET}	0.10* V _{DET}	V
Operating Current	I _{DD}	8V	No Load	-	2	3	μA
Operating Voltage	V _{DD}	-	-	1.5	-	16	V
Output Sink Current	I _{OL}	2V	V _{OUT} =0.2V	3	6	-	mA
Temperature Coefficient	$\frac{\Delta V_{DET}}{\Delta T_a}$	-	0°C <Ta<70°C	-	±0.9	-	mV/ °C



CY7070A-1XXX, Ta=25°C

Parameter	Symbol	Test Conditions		Min.	Typ.	Max.	Unit
		V _{DD}	Conditions				
Detection Voltage	V _{DET}	-	-	6.860	7.000	7.140	V
Hysteresis Width	V _{HYS}	-	-	0.02* V _{DET}	0.05* V _{DET}	0.10* V _{DET}	V
Operating Current	I _{DD}	8V	No Load	-	2	3	μA
Operating Voltage	V _{DD}	-	-	1.5	-	16	V
Output Sink Current	I _{OL}	2V	V _{OUT} =0.2V	3	6	-	mA
Temperature Coefficient	$\frac{\Delta V_{DET}}{\Delta T_a}$	-	0°C <Ta<70°C	-	±0.9	-	mV/ °C

Application Circuits

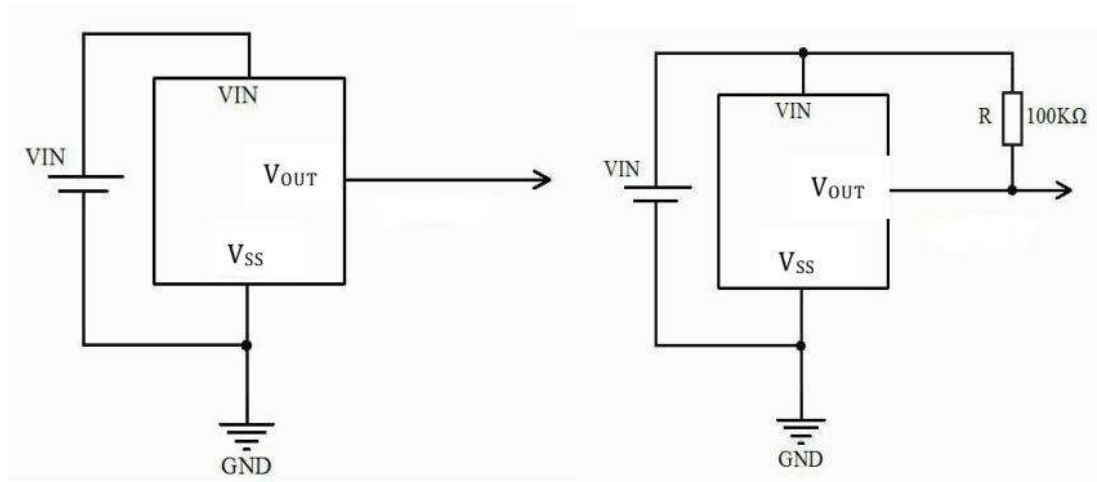

CMOS Output

N-ch Open Drain Output

Microcomputer Reset Circuit

Normally a reset circuit is required to protect the microcomputer system from malfunctions due to power line interruptions. The following examples show how different output configurations perform a reset function in various systems.

NMOS open drain output application for separate power supply:

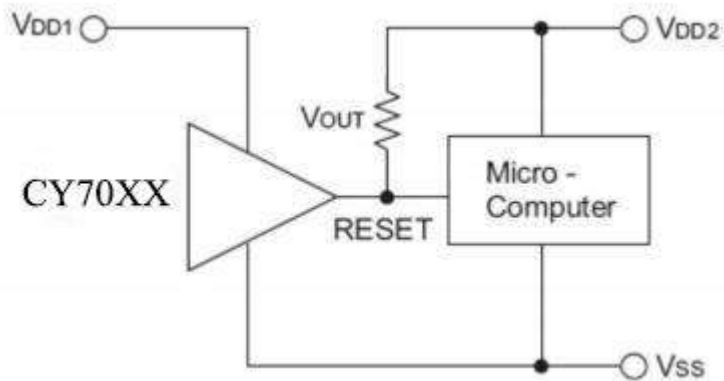

NMOS open drain output application with R-C delay:

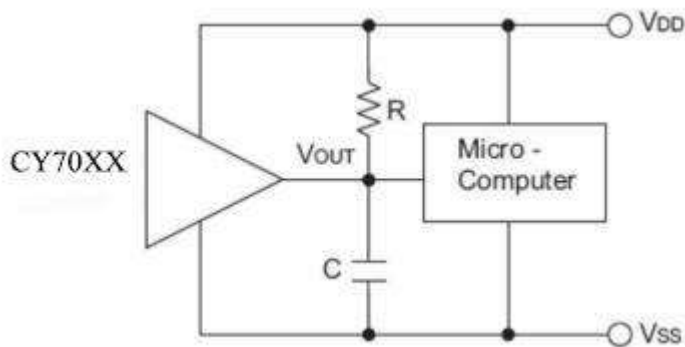

Power-on Reset Circuit

With several external components, the NMOS open drain type of the CY70XXA-1 series can be used to perform a power-on reset function as shown:

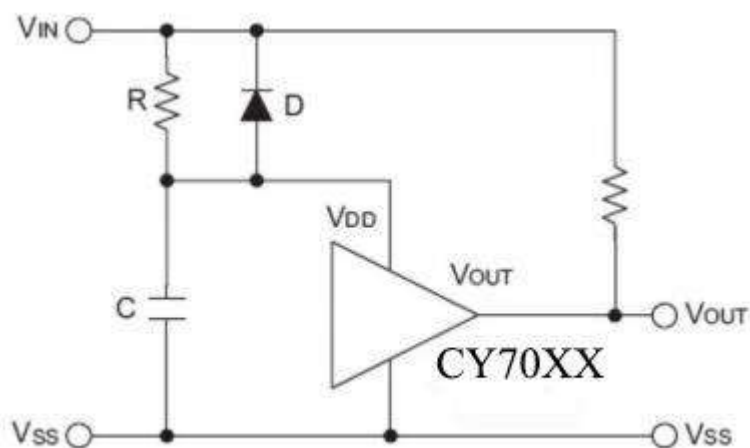

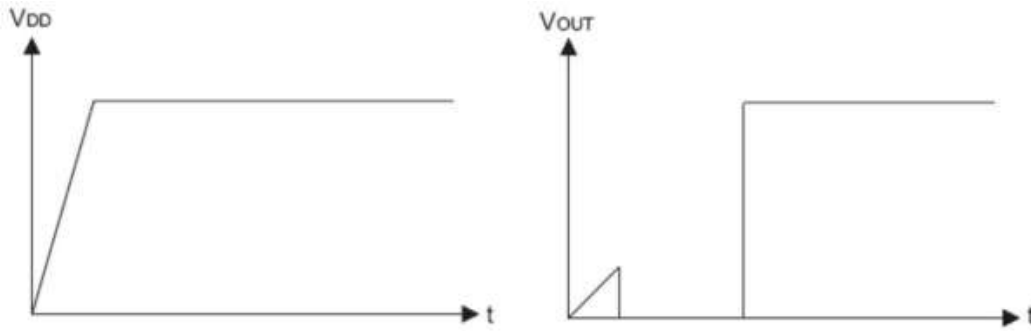

5V Power Line Monitoring Circuit

Generally, a minimum operating voltage of 4.5V is guaranteed in a 5V power line system. The CY7044A-1YTR is recommended for use as 5V power line monitoring circuit.

5V power line monitor with power-on reset:

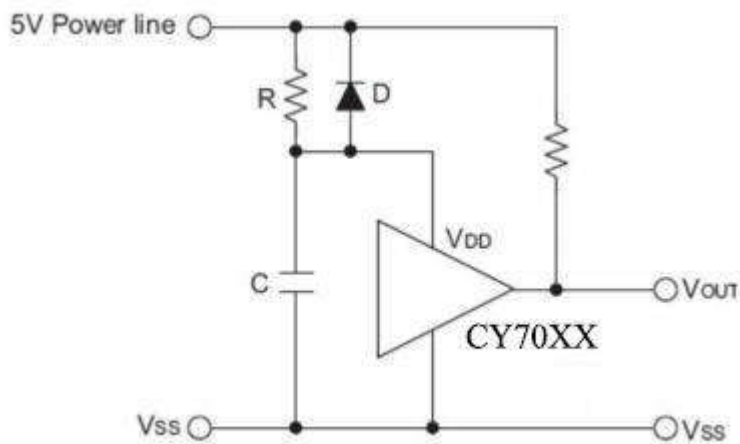

With 5V voltage regulator:

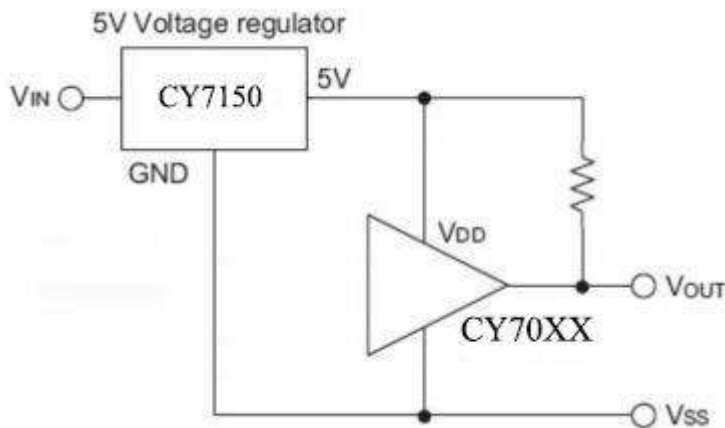

Change of Detectable Voltage

If the required voltage is not found in the standard product selection table, it is possible to change it by using external resistance dividers or diodes.

Varying the detectable voltage with a resistance divider:

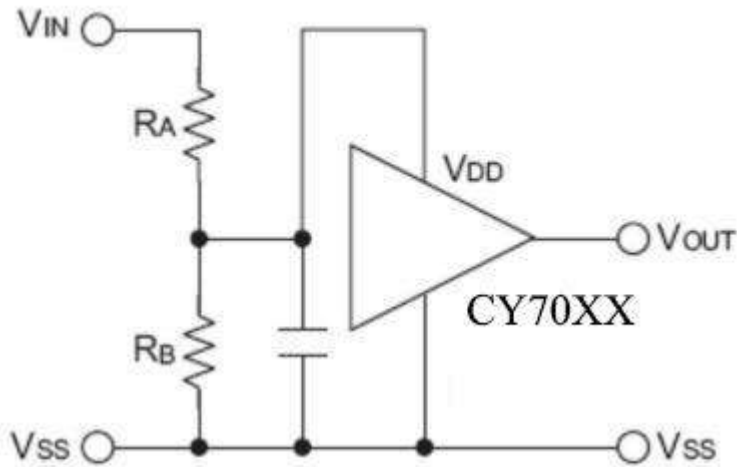

$$\text{Detectable voltage} = \frac{R_A + R_B}{R_B} \times V_{DET}$$

$$\text{Hysteresis width} = \frac{R_A + R_B}{R_B} \times V_{HYS}$$

Varying the detectable voltage with a diode:

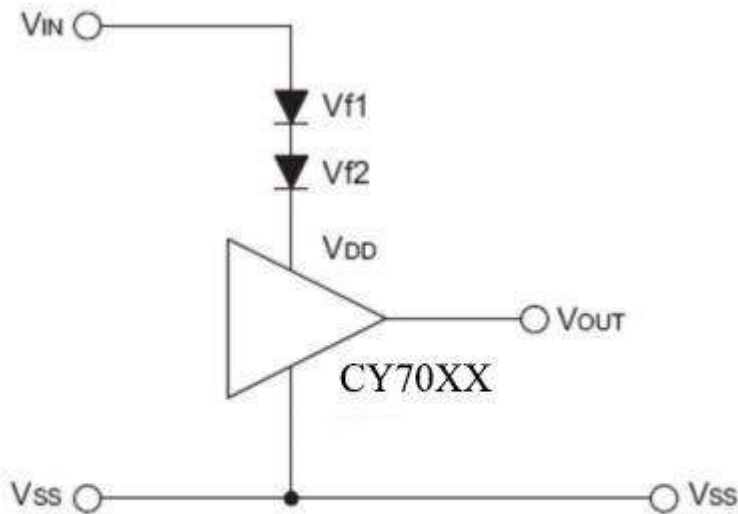

$$\text{Detectable Voltage} = V_{f1} + V_{f2} + V_{DET}$$

Malfunction Analysis

The following circuit demonstrates the way a circuit analyzes malfunctions by monitoring the variation or spike noise of power supply voltage.

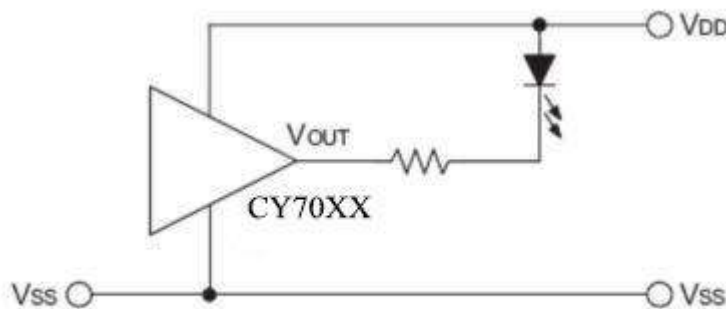

Charge Monitoring Circuit

The following circuit shows a charged monitor for protection against battery deterioration by overcharging. When the voltage of the battery is higher than the set detectable voltage, the transistor turns onto bypass the charge current, protecting the battery from overcharging.

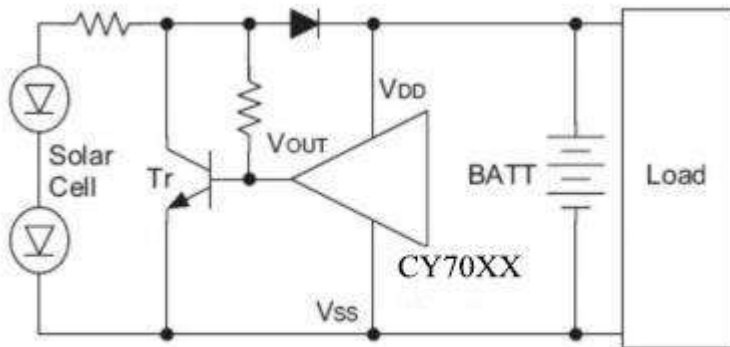

Level Selector

The following diagram illustrates a logic level selector.

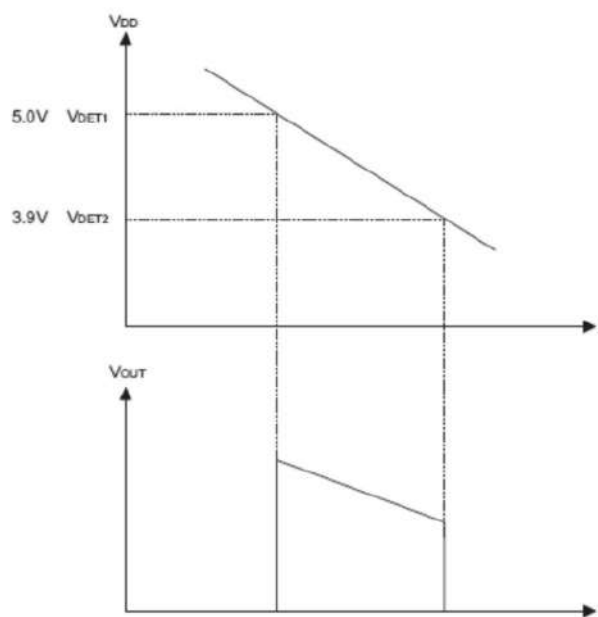
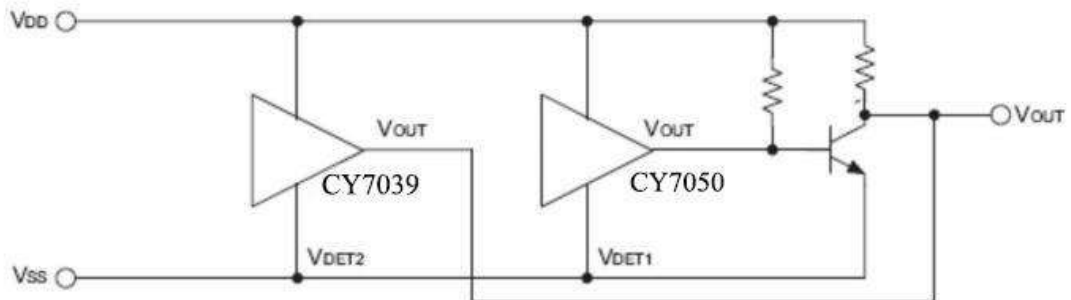



Package Information (TO92)

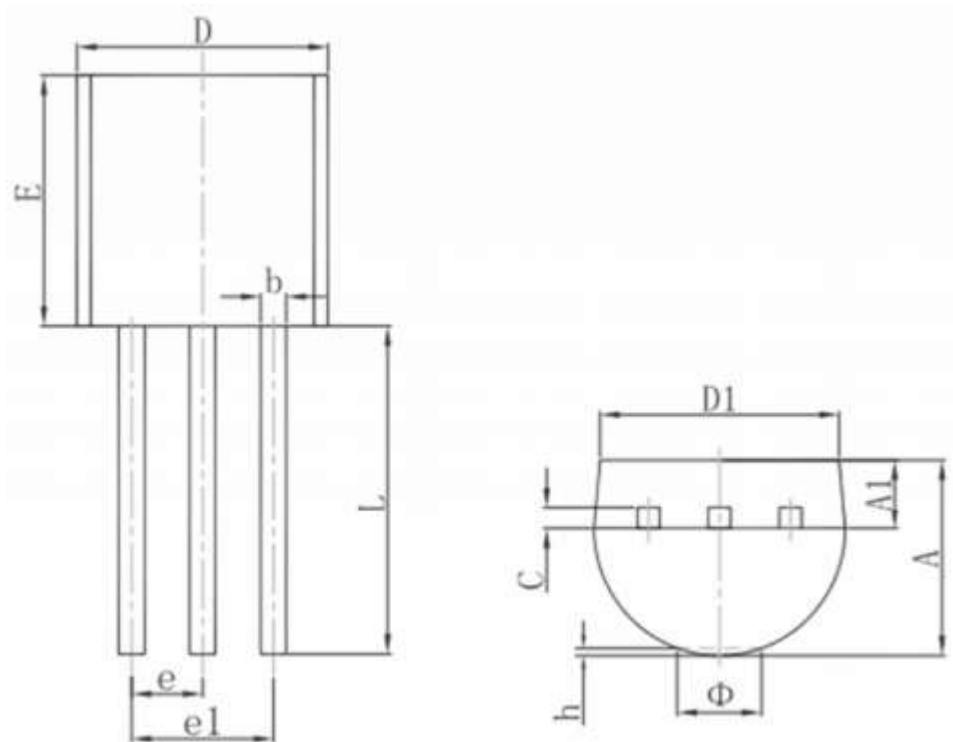

Symbol	Dimensions In Millimeters		Dimensions In Inches	
	Min.	Max.	Min.	Max.
A	3.300	3.700	0.130	0.146
A1	1.100	1.400	0.043	0.055
b	0.380	0.550	0.015	0.022
c	0.360	0.510	0.014	0.020
D	4.300	4.700	0.169	0.185
D1	3.430		0.135	
E	4.300	4.700	0.169	0.185
e	1.270TYP.		0.050TYP.	
e1	2.440	2.640	0.096	0.104
L	14.100	14.500	0.555	0.571
Φ		1.600		0.063
h	0.000	0.380	0.000	0.015

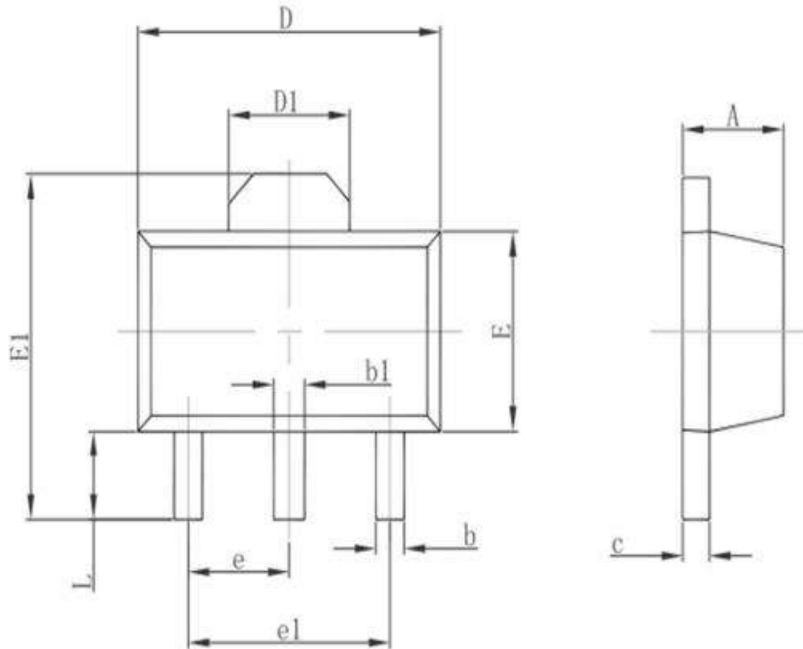
Package Information (SOT89)

Symbol	Dimensions In Millimeters		Dimensions In Inches	
	Min.	Max.	Min.	Max.
A	1.400	1.600	0.055	0.063
b	0.320	0.520	0.013	0.020
b1	0.400	0.580	0.016	0.023
c	0.350	0.440	0.014	0.017
D	4.400	4.600	0.173	0.181
D1	1.550REF.		0.061REF.	
E	2.300	2.600	0.091	0.102
E1	3.940	4.250	0.155	0.167
e	1.500TYP.		0.060TYP.	
e1	3.000TYP.		0.118TYP.	
L	0.900	1.200	0.035	0.047

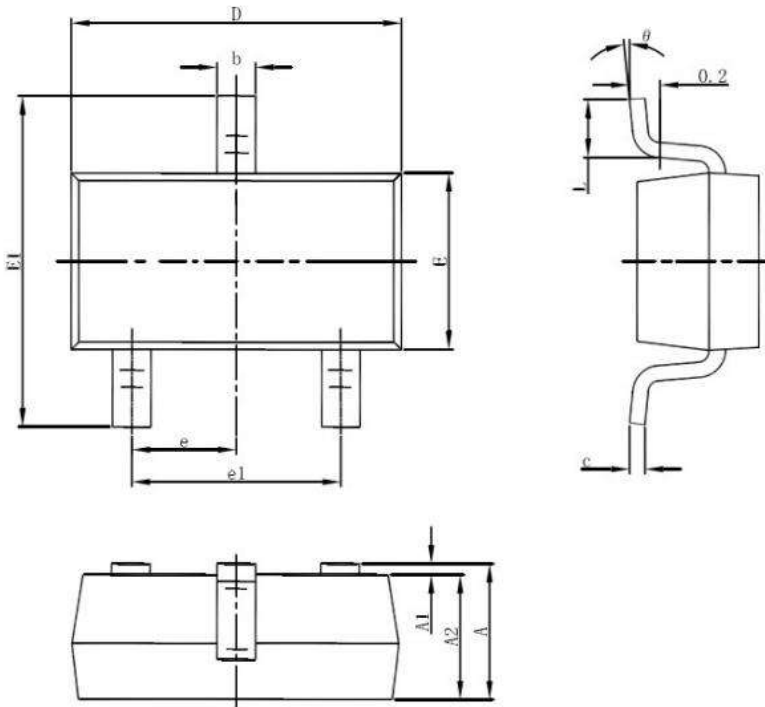
Package Information (SOT23-3)

Symbol	Dimensions In Millimeters		Dimensions In Inches	
	Min.	Max.	Min.	Max.
A	1.050	1.250	0.041	0.049
A1	0.000	0.100	0.000	0.004
A2	1.050	1.150	0.041	0.045
b	0.300	0.500	0.012	0.020
c	0.100	0.200	0.004	0.008
D	2.820	3.020	0.111	0.119
E	1.500	1.700	0.059	0.067
E1	2.650	2.950	0.104	0.116
e	0.950(BSC)		0.037(BSC)	
e1	1.800	2.000	0.071	0.079
L	0.300	0.600	0.012	0.024
θ	0°	8°	0°	8°

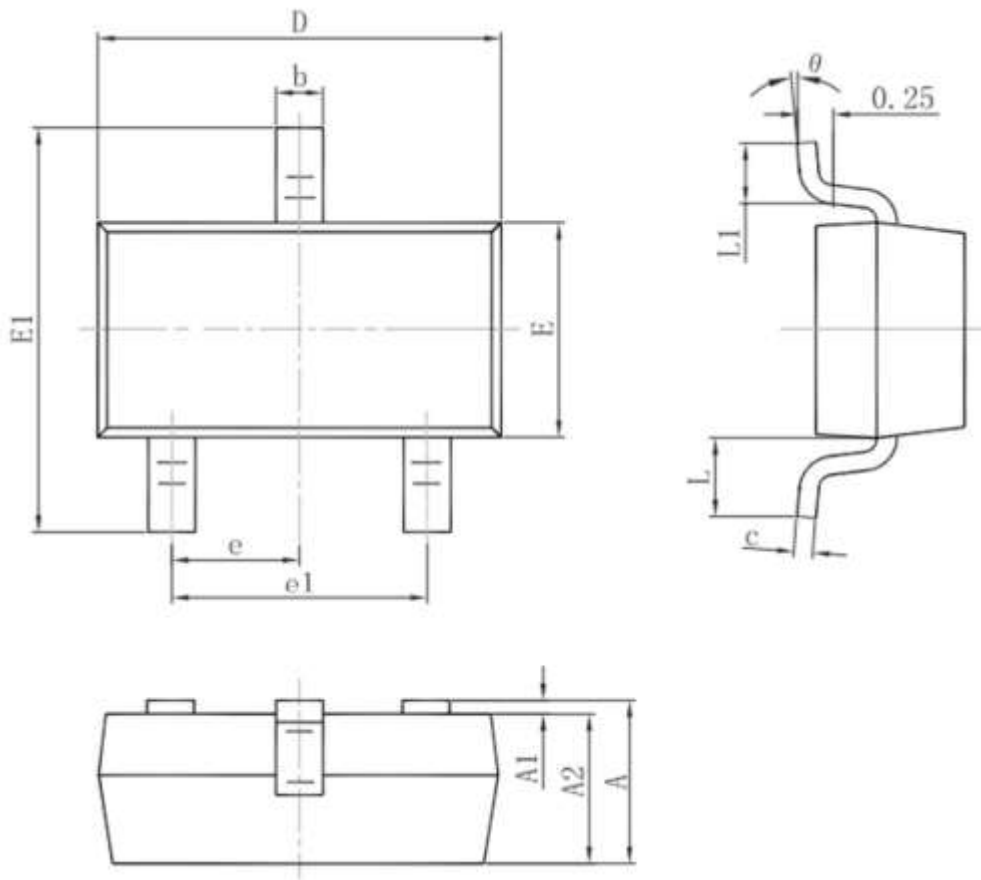
Package Information (SOT23)

Symbol	Dimensions In Millimeters		Dimensions In Inches	
	Min.	Max.	Min.	Max.
A	0.900	1.150	0.035	0.045
A1	0.000	0.100	0.000	0.004
A2	0.900	1.050	0.035	0.041
b	0.300	0.500	0.012	0.020
c	0.080	0.150	0.003	0.006
D	2.800	3.000	0.110	0.118
E	1.200	1.400	0.047	0.055
E1	2.250	2.550	0.089	0.100
e	0.950TYP.		0.037TYP.	
e1	1.800	2.000	0.071	0.079
L	0.550REF.		0.022REF.	
L1	0.300	0.500	0.012	0.020
θ	0°	8°	0°	8°