

CY Wireless Technology Limited

Single Phase Energy Meter IC with Integrated Oscillator

CYP1837 Datasheet



Date: 2021/09/08

Version: 1.03

General Description

CYP1837 is a wide range of single-phase multi-function energy meter IC for single-phase socket, single-phase strip, Smart Appliance, with a low cost and high accuracy.

CYP1837 integrates two high-accuracy Sigma-Delta ADC, voltage reference, power management and other analog circuit modules, and digital signal processing circuit to calculate active power, IRMS, VRMS etc. High frequency CF1 is provided for indicating IRMS/VRMS and high frequency CF for energy metering.

CYP1837 can measure the single-phase active energy, active power, current and voltage RMS and other parameters to fully meet the needs of the socket, power strip, smart appliances and others.



Features

- High accuracy, less than $\pm 0.5\%$ error over a dynamic range of 2500: 1
- High stability of large signal, in the condition of signal 300mA, less than $\pm 0.2\%$ error in the output frequency fluctuation (CF)
- High stability of small signal, in the condition of signal 50mA, less than $\pm 0.3\%$ error in the output frequency fluctuation (CF)
- Current and voltage RMS, current measurement range (4mA ~ 30A) @1mohm
- On-Chip anti-creep protection, Ensure noise power removal when there is no current
- On-Chip power supply detector. Detect power down state, the chip goes into a reset state when the operating voltage drops below 2.7V
- On-Chip voltage reference of 1.2V(typical)
- On-chip oscillator as clock source, the clock about 2 MHZ
- Single 3.3V supply, low power (8 mW typical)
- Package: SOP8

2.Applications

- Electric instrument
- Intelligent socket, intelligent circuit breaker
- Intelligent electric energy acquisition terminal

Order specification

Part No	Package	Manner of Packing	Devices per bag/reel
CYP1837	SOP8	Reel	2500PCS

Block Diagram

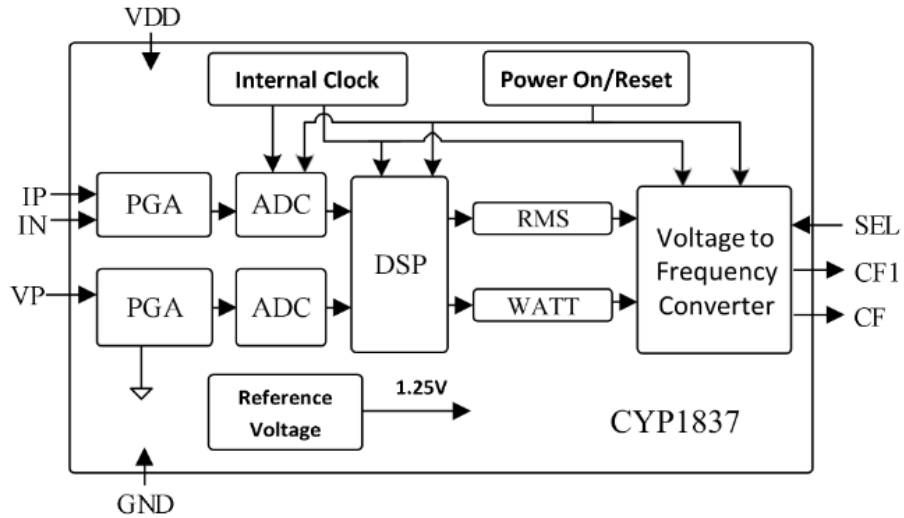

Pin Assignment

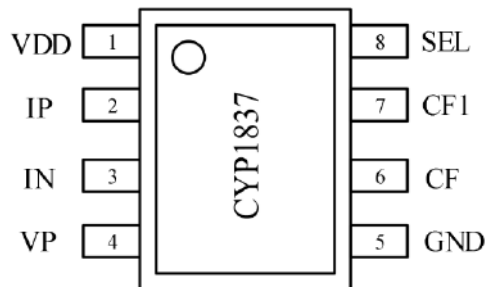

SOP-8

Pin No.	Pin Name	Description
1	VDD	Power Supply (+3.3V). It should be maintained at 3.0V~3.6V when IC is working.
2, 3	IP, IN	Inputs for Current Channel. These inputs are fully differential voltage inputs with a maximum signal range of $\pm 50\text{mV}$. Due to the internal ESD protection circuit, if the voltage overvoltage is $\pm 1.5\text{V}$, there will still not be too much damage.
4	VP	Positive Input for Voltage Channel. The Voltage Inputs is differential voltage inputs with a maximum signal range of $\pm 200\text{mV}$. (As above, the maximum signal amplitude is $\pm 1.5\text{V}$)
5	GND	Ground Reference.
6	CF	High frequency pulse output for active power, the high pulse width is fixed to 38uS; the frequency is proportional to the active power value. Over-current indication pin; If over-current occurs, the pin output 7.17KHz pulse.



7	CF1	SEL=0, the output indicates current RMS, high pulse width is fixed to 38uS,The frequency is proportional to the current RMS value; SEL=1, the output indicates voltage RMS, high pulse width is fixed to 38uS,The frequency is proportional to the voltage RMS value;
8	SEL	CF1 output select PIN. Internal pull-down resistor.

Absolute Maximum Ratings

Parameter	Symbol	Value	Unit
Power Voltage VDD	VDD	-0.3~+4	V
Analog Input Voltage to GND	IP~IN,VP	-4~+4	V
Digital Voltage to GND	SEL, CF,CF1	-0.3~VDD+0.3	V
Operating Temperature Range	T	-40~+85	°C
Storage Temperature Range	T	-40~+85	°C
Dissipation power of SOP8	Pd	10	mW

Note: Unless specified otherwise, Tamb= 25°C

Electrical Characteristics

Parameter	Symbol	Test Conditions	Measure Pin	Min	Typ	Max	Unit
Power Supply	VDD			3.0		3.6	V
Power Dissipation	Iop	VDD=3.3V			3		mA
Measure Error on Active Power(Absolute error)	WATTerr	a dynamic range 2500 to 1	CF		0.3	0.5	%
Measure fluctuation error on Active Power (Large signal)	Δ @6%Ib, Ib=5A	300mA@ 1mohm sample resistance , test 2-turn average	CF		0.1	0.2	%
Measure fluctuation error on Active Power (Small signal)	Δ @1%Ib, Ib=5A	50mA @ 1mohm sample resistance, test 1-turn	CF		0.15	0.3	%
Phase error when PF=0.8 Capacitive	PF08err	Current lead 37° (PF=0.8)				0.5	%
Phase error when PF=0.5Inductive	PF05err	Current lags 60° (PF=0.5)				0.5	%
AC PSRR	ACPSRR	IP/N=100mV				0.1	%
DC PSRR	DCPSRR	VP/N=100mV				0.1	%
Vrms measurement Error	VRMSerr		CF1		0.3		%
Irms measurement Error	IRMSerr	Ib	CF1		0.3		%
Analog Input Voltage(current)		Current differential input (peak)				50	mV
Analog Input Voltage(voltage)		voltage differential input (peak)				200	mV
Analog Input Impedance			VP/IP/IN		370		kΩ



SEL pull-down resistor		SEL ((pull-down)			80		kΩ
Input Signal Bandwidth		(-3dB)			3.5		kHz
On-chip voltage reference	Vref		VREF		1.218		V
Input High Voltage		VDD=3.3V ±5%		2.6			V
Input Low Voltage		VDD=3.3V ±5%				0.8	V
Output High Voltage		VDD=3.3V ±5% IOH=5mA		VDD -0.5			V
Output Low Voltage		VDD=3.3V ±5% IOL=5mA				0.5	V
Over-current threshold		Current sampling resistor 1mΩ				36	A
the frequency of over-current						7.17	KHz
response time of Over-current						200	ms

Note: Unless specified otherwise, Tamb = 25°C

All voltage values take GND terminal potential as reference point.

Test conditions VDD = 3.3V, built-in 2M crystal oscillator.

Theory of Operation

Principle of Energy Measure

In energy measure, the power information varying with time is calculated by a direct multiplication of the voltage signal and the current signal. Assume that the current signal and the voltage signal are cosine functions , the phase difference between the current signal and the voltage signal is expressed as Φ . Then the power is given as follows:

$$p(t) = V \cos(\omega t) \times I \cos(\omega t + \Phi)$$

$\Phi = 0 :$

$$p(t) = \frac{VI}{2} (1 + \cos(2\omega t))$$

$\Phi \neq 0 :$

$$\begin{aligned} p(t) &= V \cos(\omega t) \times I \cos(\omega t + \Phi) \\ &= V \cos(\omega t) \times [I \cos(\omega t) \cos(\Phi) + \sin(\omega t) \sin(\Phi)] \\ &= \frac{VI}{2} (1 + \cos(2\omega t)) \cos(\Phi) + VI \cos(\omega t) \sin(\omega t) \sin(\Phi) \\ &= \frac{VI}{2} (1 + \cos(2\omega t)) \cos(\Phi) + \frac{VI}{2} \sin(2\omega t) \sin(\Phi) \end{aligned}$$

p(t) is called as the instantaneous power signal. The ideal p(t) consists of the dc component and ac component whose frequency is 2ω .The former is also called instantaneous real power signal, instantaneous real power is the primary object of electricity meter measurement.



The current and voltage signals are sampled with high precision and converted from analog signals to digital signals. The instantaneous power signal $p(t)$ is obtained after the digital signals are calculated by digital multiplier. Let $p(t)$ pass through a straight-cut low-pass filter with a very low cutoff frequency (e.g., 1Hz) to take out the real-time real power signal. Then the real power signal is integrated with time to obtain the energy information. If choose the integration time is very short, it can get the information of the immediate energy consumption, which can also be considered as the information of the immediate power consumption, because the two are proportional to each other. If the longer integration time is selected, the information obtained is the average energy consumption, which can also be considered as the information of the average power consumption.

In order to extract the real power component (i.e., the dc component), the instantaneous power signal is low-pass filtered, and then accumulated (e.g., by a counter) to generate real energy information. This information is sent to the digital-to-frequency converter module, and converted to a pulse signal of the certain frequency which is proportional to the real power.

Similarly, the voltage and current RMS are calculated and then sent to the digital-to-frequency converter module, converted to a pulse signal of the certain frequency which is proportional to the voltage and current RMS.

Power Supply Monitor

CYP1837 contains an on-chip power supply monitor. The power supply (VDD) is continuously monitored by CYP1837. if the supply is less than $2.7V \pm 5\%$, CYP1837 will be not activated (not working).In other words, when the supply voltage is less than 2.7V, no energy accumulation is carried out.This is useful to ensure correct device startup at power-up and power-down. The power supply monitor has built in hysteresis and filtering. This prevents wrong triggering which might be induced by noisy jamming. Generally, the decoupling part of power supply should ensure that the ripple on VDD does not exceed $3.3V \pm 5\%$.

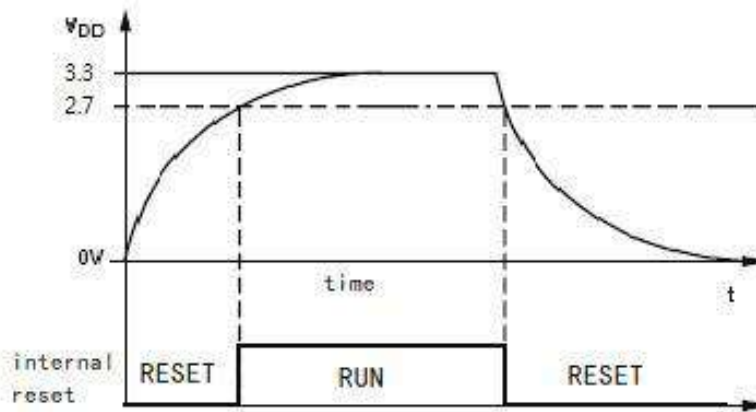

Internal Power Supply Monitor

APPLICATIONS

CYP1837 Typical Application

CYP1837 Typical application block diagram is shown below. Single 3.3V supply. The current signal is sampled through the alloy resistor connected to the IP and IN pins of CYP1837. The voltage signal is sampled through the resistor divider network connected to the VP pin of CYP1837. CF, CF1, SEL directly access to the MCU pin. CF/CF1 pulse cycle is measured to calculate the power, current RMS and voltage RMS.

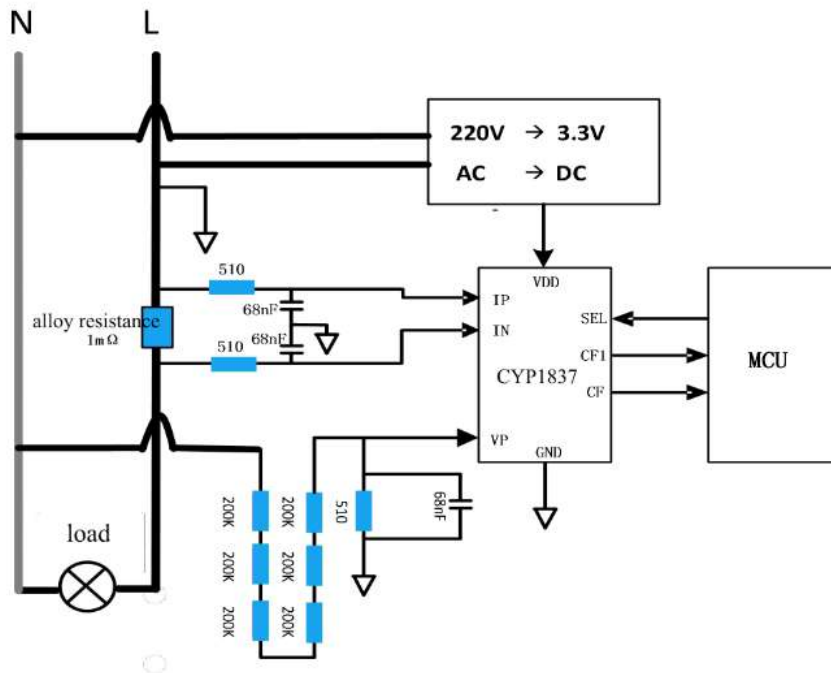

CF、CF1 frequency

CYP1837 measures two voltage signals on current channel and voltage channel and then calculates the real power information. This real power information is then converted to a frequency. The frequency information is output on CF in the form of active high pulses. At the same time current RMS and voltage RMS are calculated and converted to a frequency, and output on CF1 in the form of active high pulses.

(1) active power pulse frequency formula(typical):

$$F_{CF} = 2423325 * \frac{V(V) * V(I)}{V_{ref}^2}$$

(2) voltage RMS pulse frequency formula(typical):

$$F_{CFV} = 20227 * \frac{V(V)}{V_{ref}}$$

(3) current RMS pulse frequency formula(typical):

$$F_{CFI} = 120238 * \frac{V(I)}{V_{ref}}$$

V(V)——the voltage RMS of the voltage channel V(I)——the voltage RMS of the current channel Vref——reference voltage (1.218V)



Anti-creep

CYP1837 has a patented anti-creep design with a reasonable external hardware design to ensure that the noise power is not included in the energy pulse in no load. The anti-creep threshold is 0.0035% of the active power corresponding to the full-scale input signal.

Over-current detection

CYP1837 has fast over-current detection function. CYP1837 can detect the over-current within 200ms. The pin CF would output over-current signal when over-current occurs. This function helps to design the over-current protection circuit.

Current/voltage RMS output

The current / voltage RMS is output from the pin CF1. When SEL = 0, the CF1 outputs a high frequency pulse of the current RMS; When SEL = 1, the CF1 outputs a high frequency pulse of the voltage RMS. The current and voltage RMS calculation modules are separate internally. SEL switching time < 10uS.

Package Information (SOP-8)

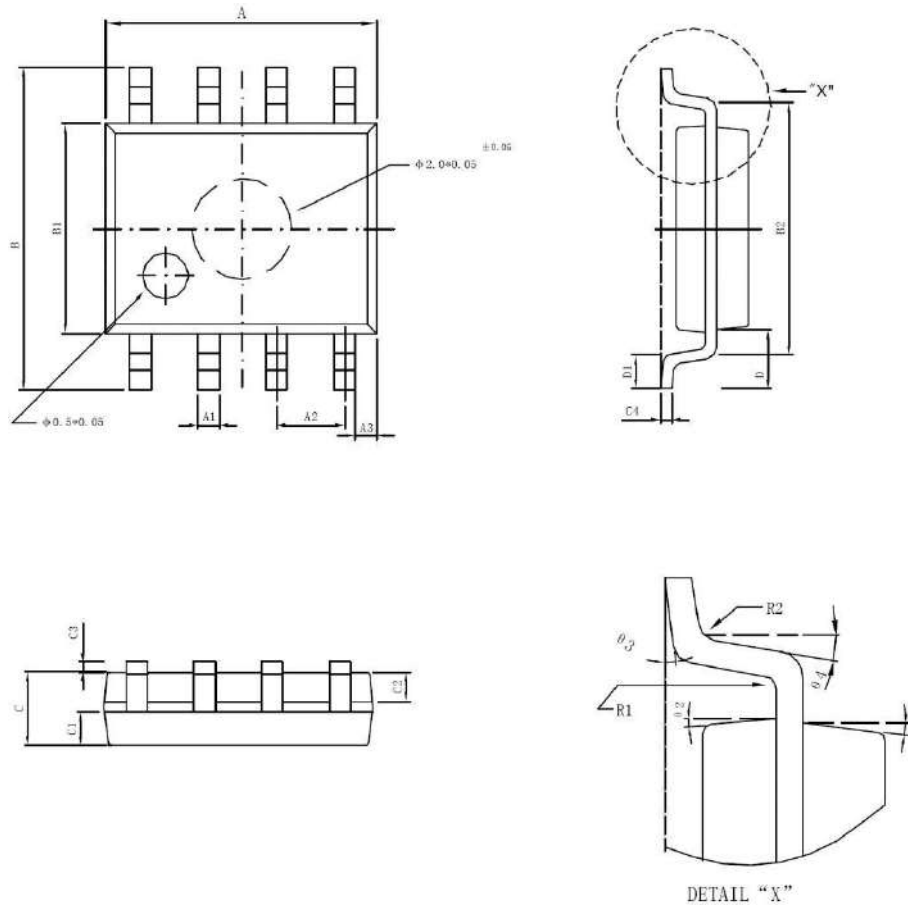

Symbol	Min. (mm)	Max. (mm)	Symbol	Min. (mm)	Max. (mm)
A	4.95	5.15	C3	0.10	0.20
A1	0.37	0.47	C4	0.20TYP	
A2	1.27TYP		D	1.05TYP	
A3	0.41TYP		D1	0.50TYP	
B	5.80	6.20	R1	0.07TYP	
B1	3.80	4.00	R2	0.07TYP	
B2	5.0TYP		θ_1	17°TYP	
C	1.30	1.50	θ_2	13°TYP	
C1	0.55	0.65	θ_3	4°TYP	
C2	0.55	0.65	θ_4	12°TYP	



Special Instructions

The company reserves the right of final interpretation of this specification.

Version Change Description

Version: V1.03

Author: Yangyang

Time: 2021.9.08

Modify the record:

1. Re-typesetting the manual and checking some data
 2. The coefficient of calculation formula is changed as follows: ① The power calculation coefficient is updated from 1721506 to 2423325; ② Voltage calculation coefficient is updated from 15397 to 20227; ③ The current calculation coefficient is updated from 94638 to 120238
 3. CF pin frequency was updated from 6.78khz to 7.17khz during over current output
 4. The marking of the new version starts from CYP1837 240BHEC, The letter "B" in the marking represents the new version
-

Statement

The information in the usage specification is correct at the time of publication, CY Wireless Technology Limited has the right to change and interpret the specification, and reserves the right to modify the product without prior notice. Users can obtain the latest version information from our official website or other effective channels before confirmation, and verify whether the relevant information is complete and up to date.

With any semiconductor product, there is a certain possibility of failure or failure under certain conditions. The buyer is responsible for complying with safety standards and taking safety measures when using the product for system design and complete machine manufacturing. The product is not authorized to be used as a critical component in life-saving or life-sustaining products or systems, in order to avoid potential failure risks that may cause personal injury or property loss.